

Blackline Masters

The blackline masters provide an important tool for whichever mode of instruction you use. For easy accessibility, reproducible copies of these special types of graph paper appear at the beginning of the section:

- *Dot graph paper* that students will find useful for sketching graphs they have plotted on their graphers, particularly if they have used the GRID ON option. The six grids on each sheet have the same proportions as the screen of a typical graphing calculator.
- *Centimeter graph paper*, on which students can plot accurate figures, such as the triangles of Chapter 6, and measure the angles and side lengths to verify calculated values.
- *Log-log and semilog graph paper* for use in Chapter 8. Power function graphs are straight on log-log paper, and exponential function graphs are straight on semilog paper. Logarithmic function graphs are straight on semilog paper rotated 90 degrees clockwise.
- *Polar coordinate paper* for use in Chapter 13, with six polar grids per sheet, making them large enough to see easily but not so large that students have difficulty drawing on them.

Many of the problems in the text call for students to draw accurately on a copy of a graph that appears in the text. The graphs in the Blackline Masters section are grouped according to the problem set in which they appear. For instance, if students are working on composition of ordinates and harmonic analysis in Section 5-4, all of the graphs they need are on the same sheet or sheets. You can photocopy these sheets and distribute them to students as you assign the particular problem set. Students find that these graphs assist their work and reduce the incentive to mark up their textbooks.

The blackline masters may also be used to make transparencies of the graphs to assist your development of a topic. The transparencies can also be used for presentation of homework problems in class the following day.

Name: _____ Group Members: _____

Dot Graph Paper

Date: _____

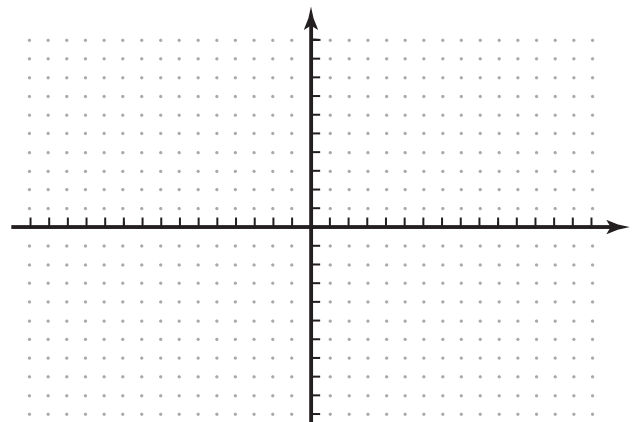
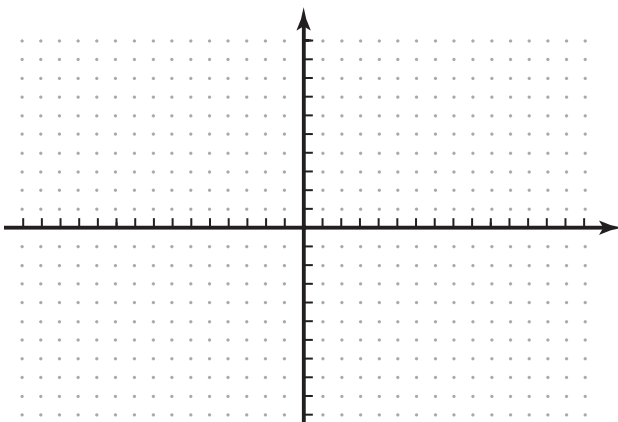
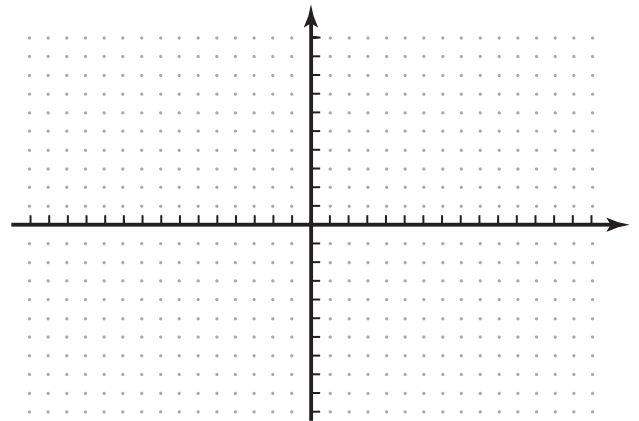
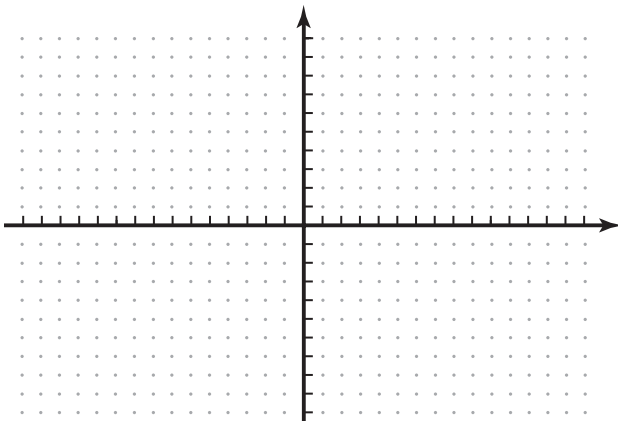
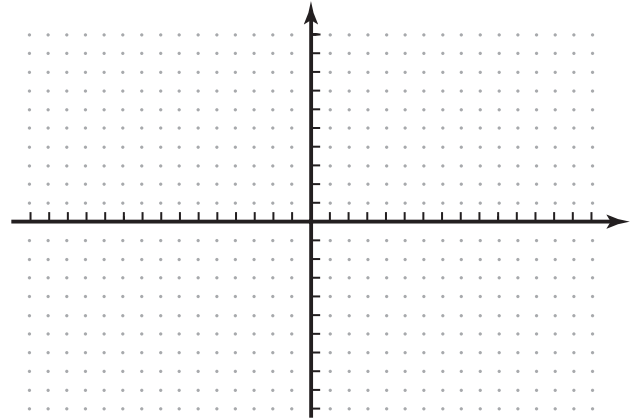
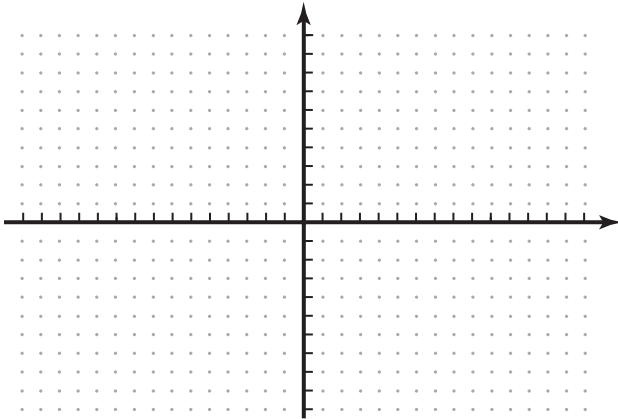

Name: _____ Group Members: _____

Centimeter Graph Paper

Date: _____

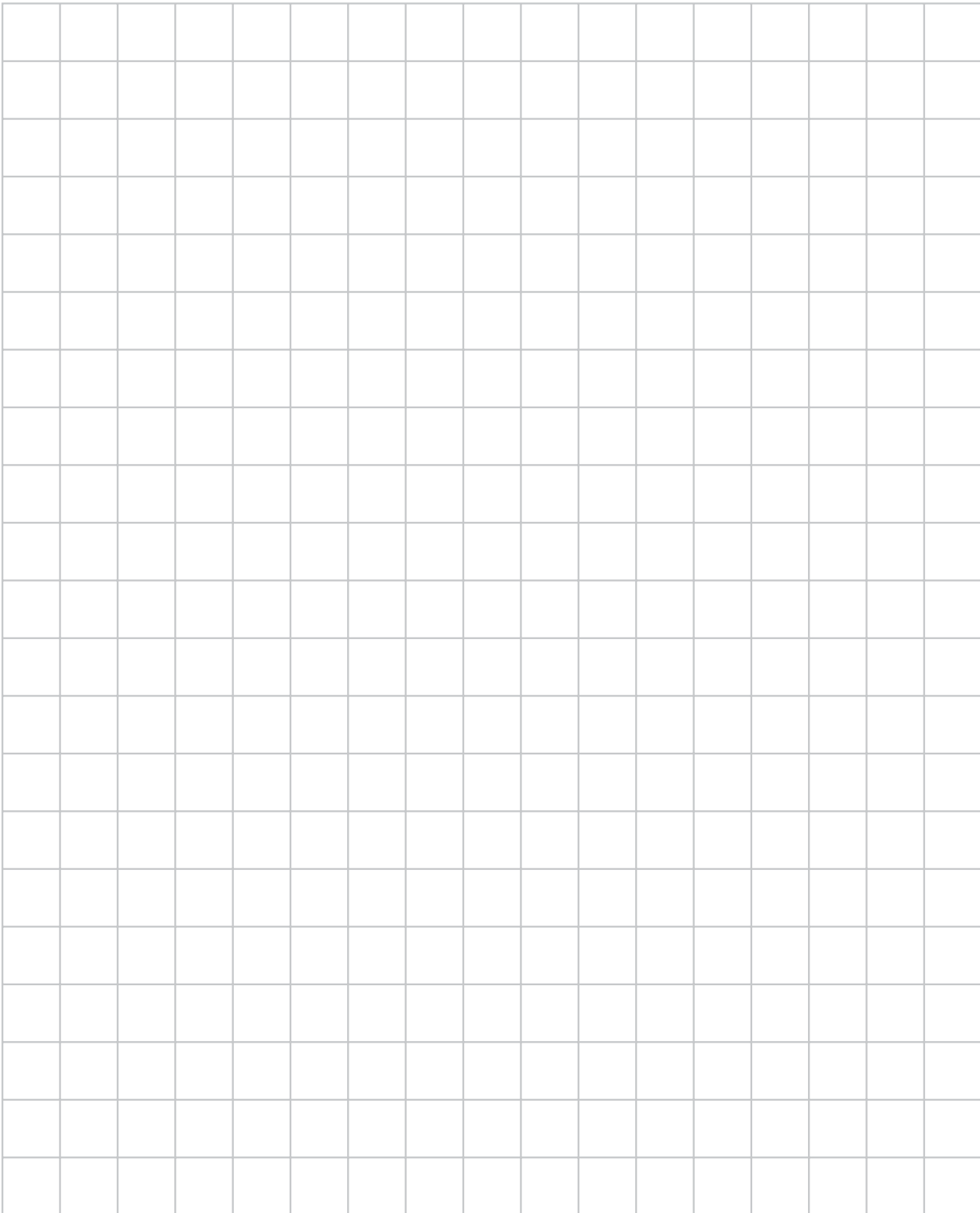

Name: _____ Group Members: _____

Log-log Graph Paper

Date: _____

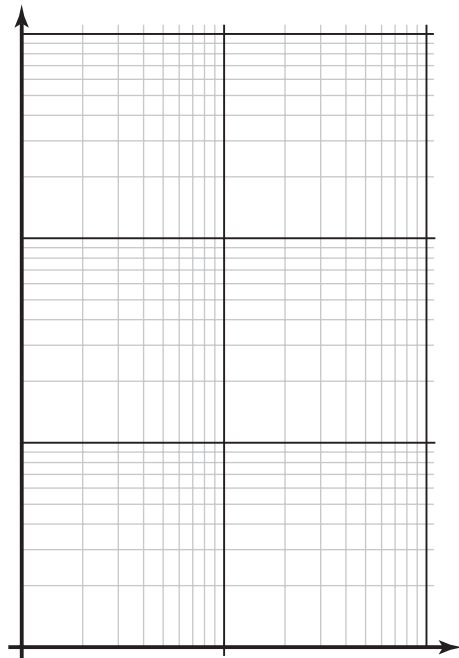
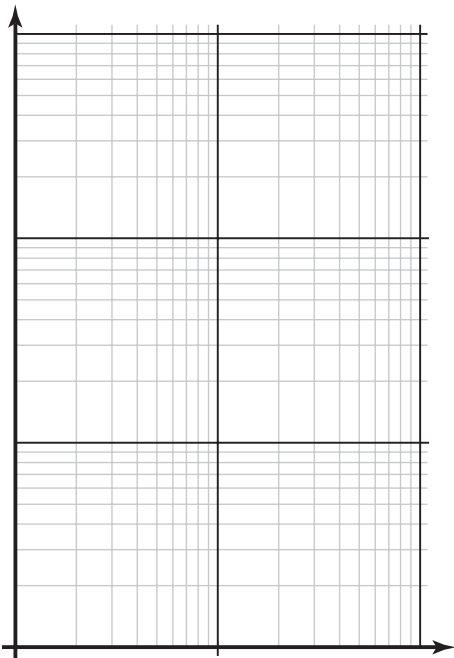
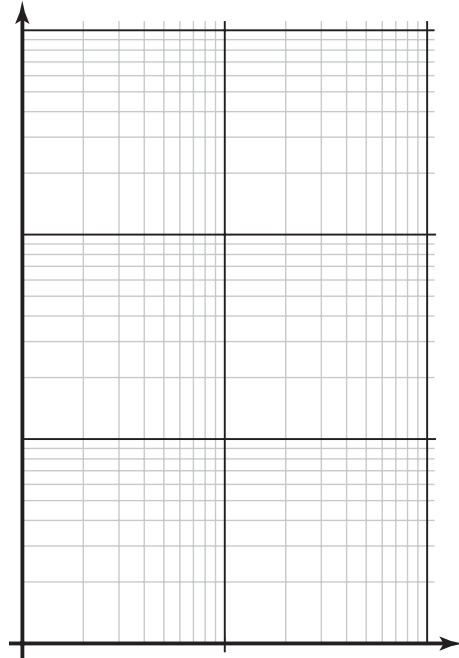
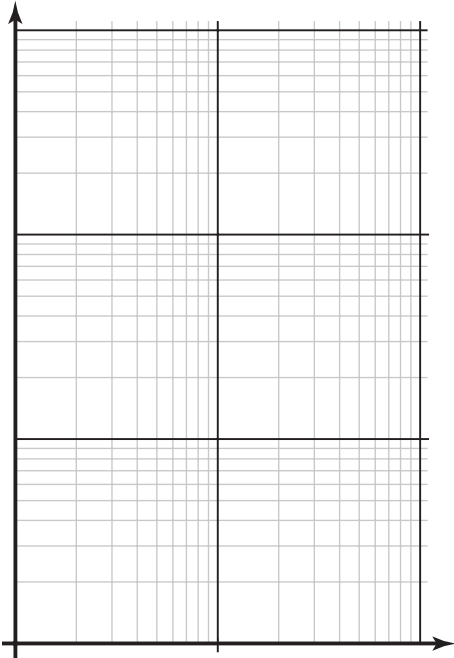

Name: _____ Group Members: _____

Semilog Graph Paper (Add-multiply)

Date: _____

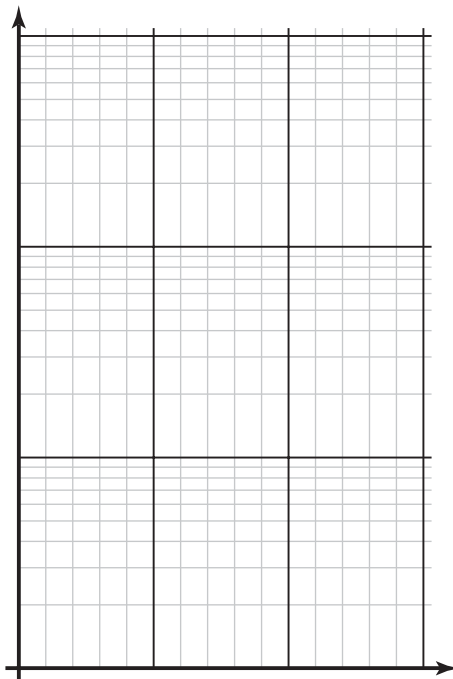
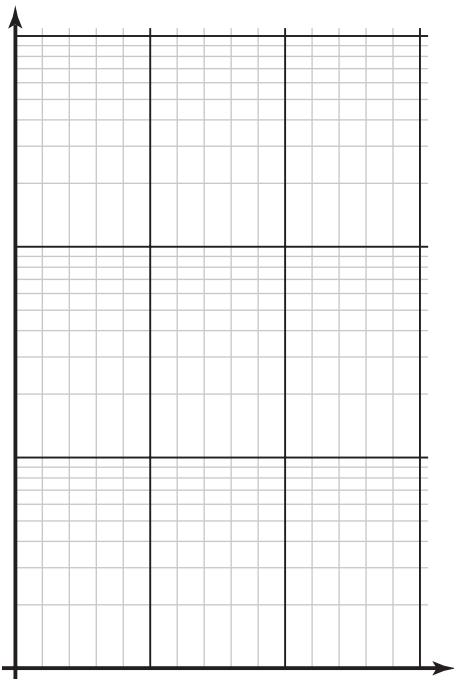
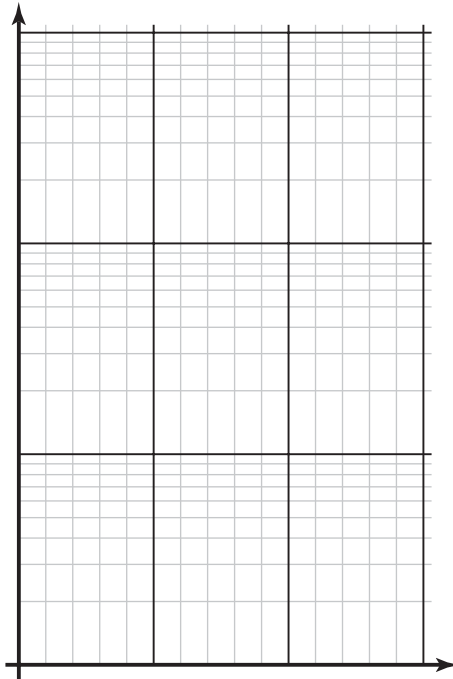
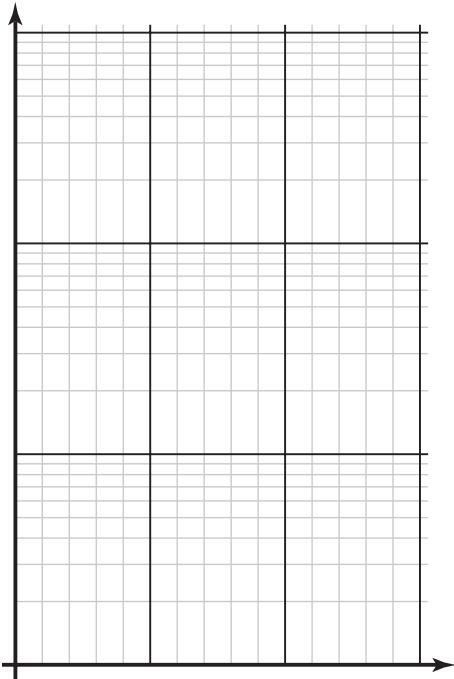

Name: _____ Group Members: _____

Semilog Graph Paper (Multiply-add)

Date: _____

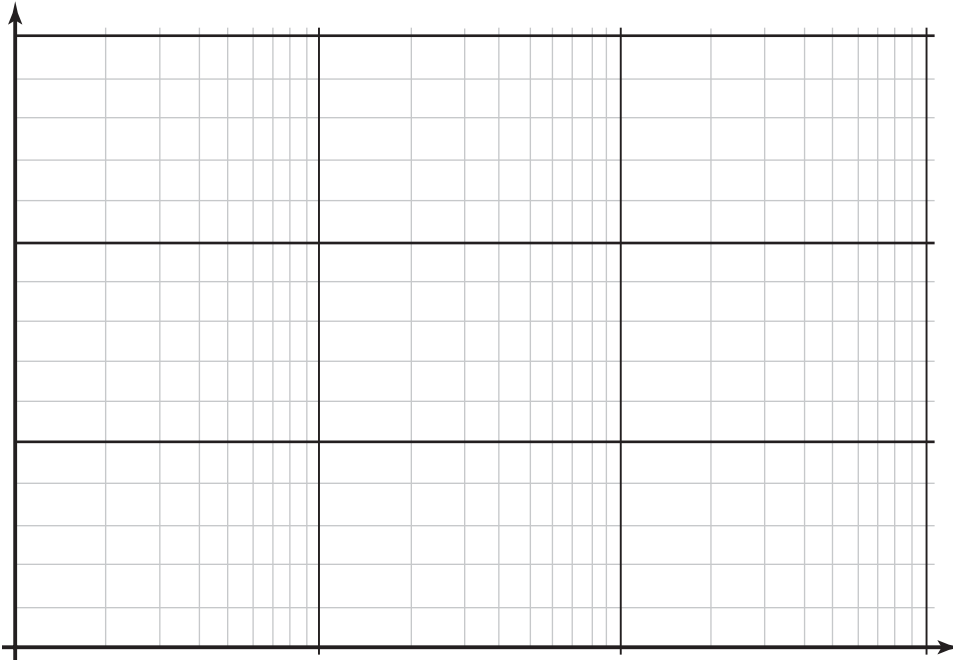
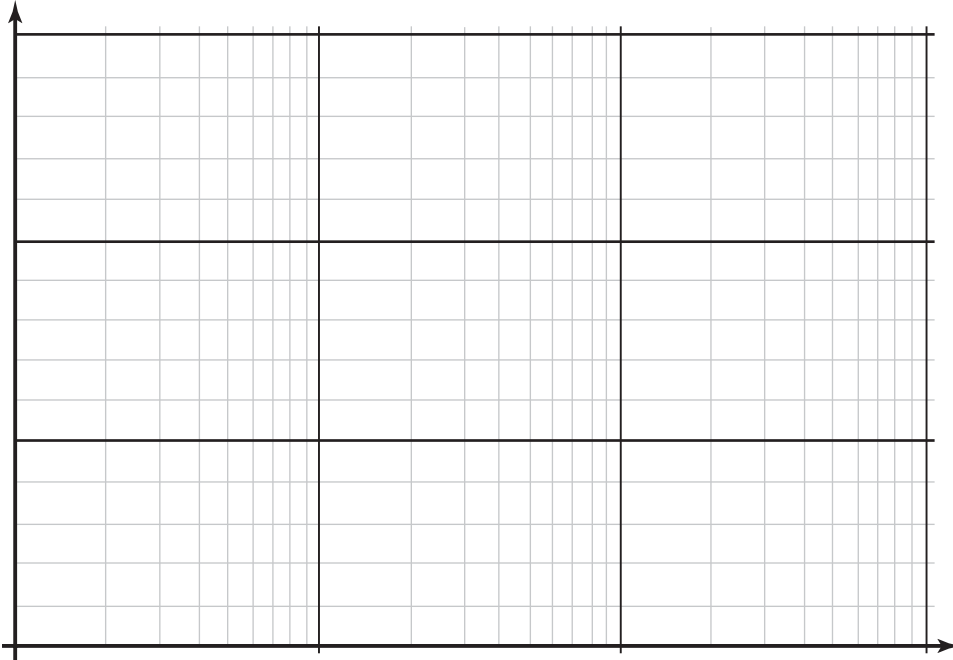

Name: _____ Group Members: _____

Polar Coordinate Paper

Date: _____

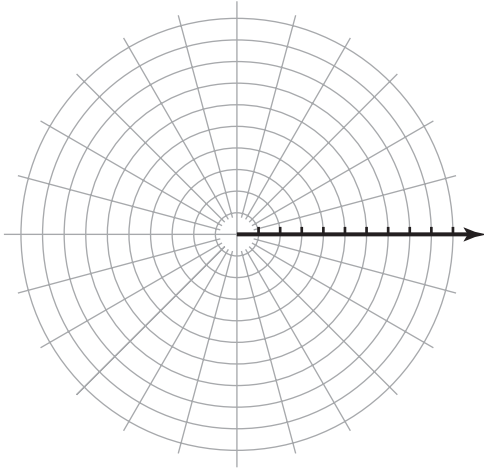
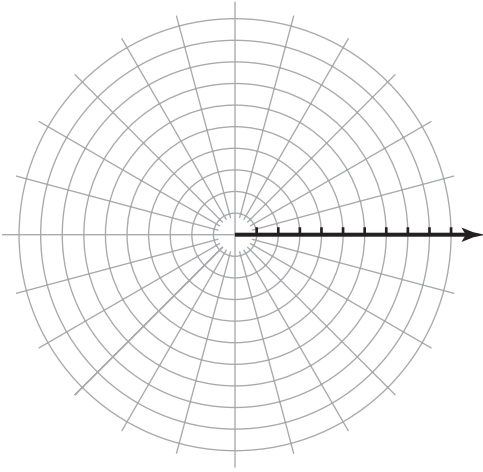
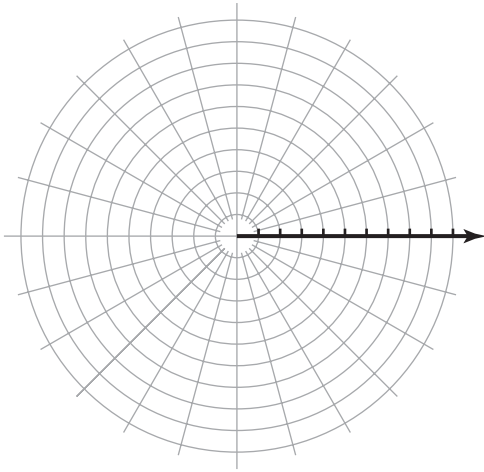
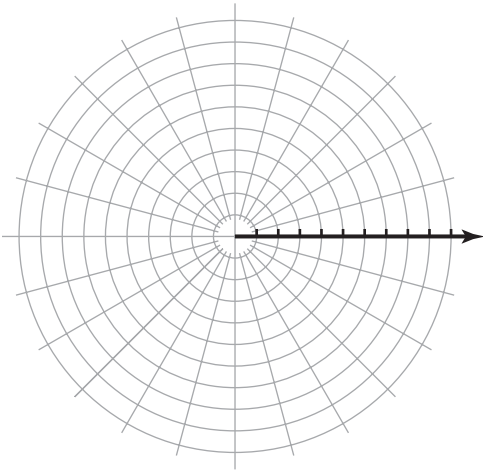
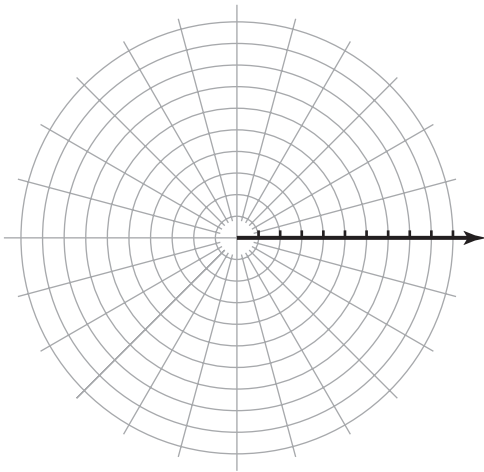
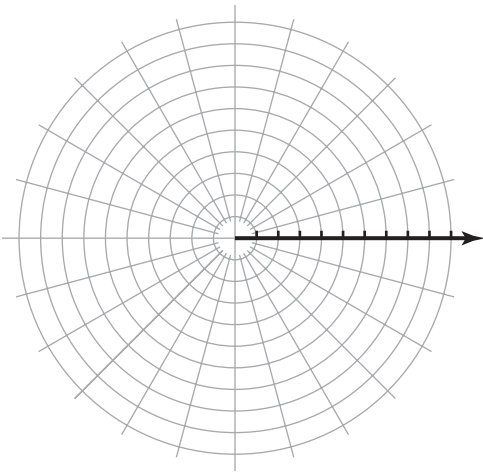

Problem Set 1-3/Page 21

15a.

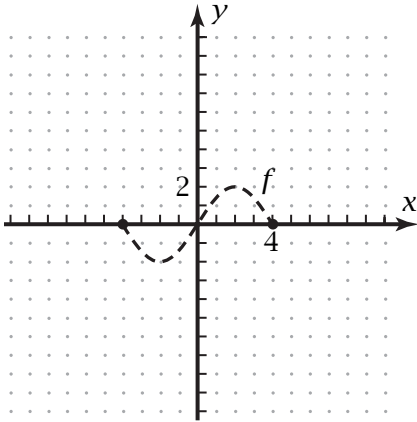

Figure 1-3h

18a.

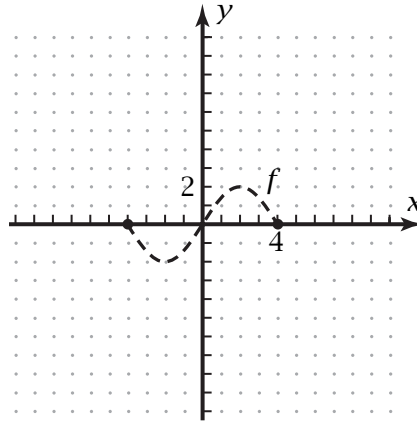

Figure 1-3h

16a.

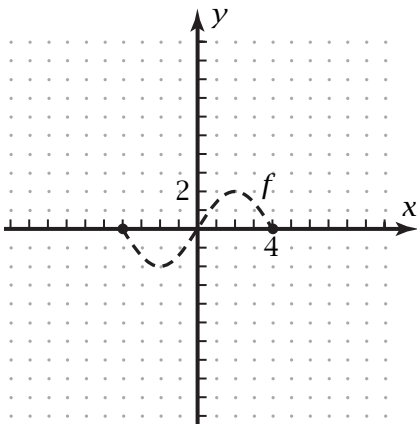

Figure 1-3h

19a.

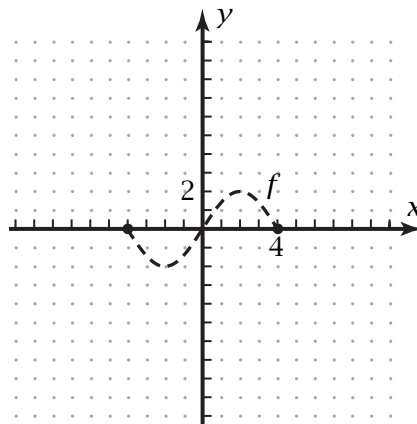

Figure 1-3h

17a.

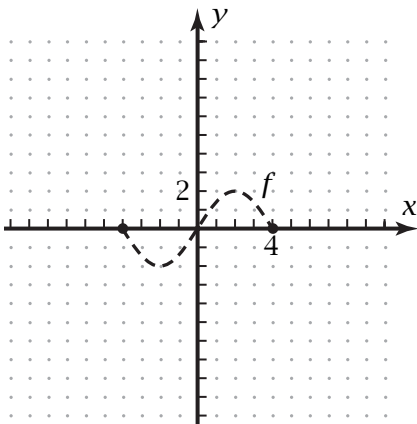

Figure 1-3h

20a.

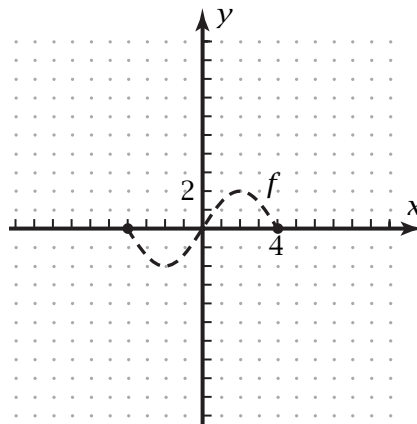

Figure 1-3h

Problem Set 1-4/Pages 30-31

5.

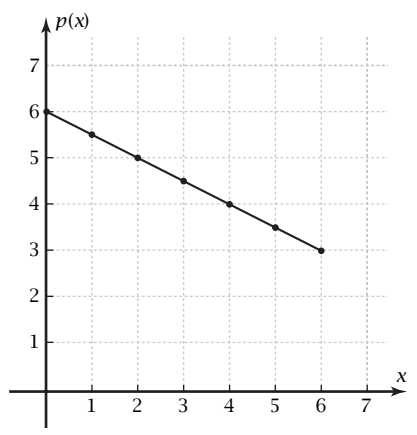
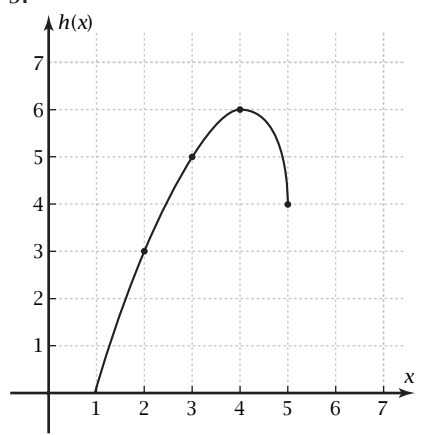

Figure 1-4j

6.

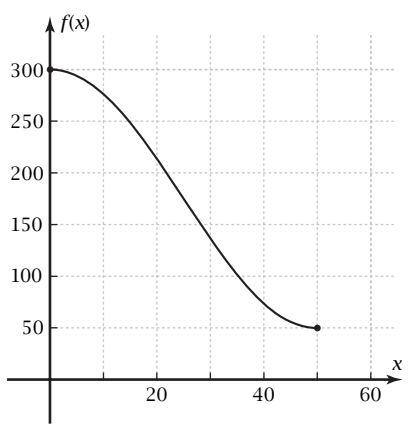
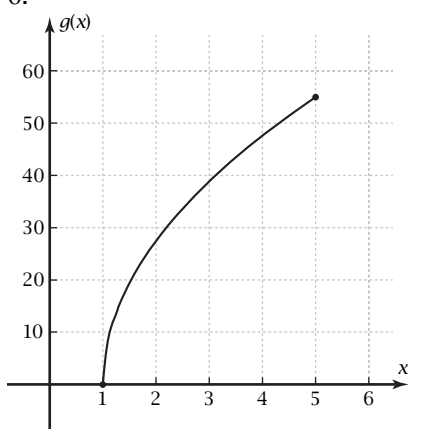
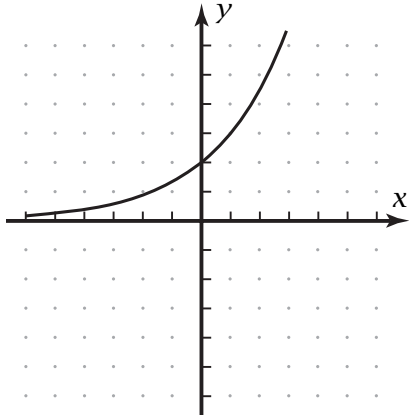

Figure 1-4k

Problem Set 1-5/Page 41

5.



7.

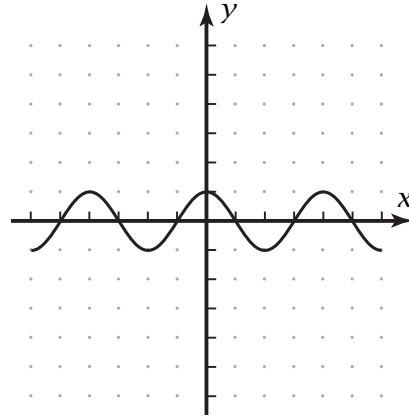

6.

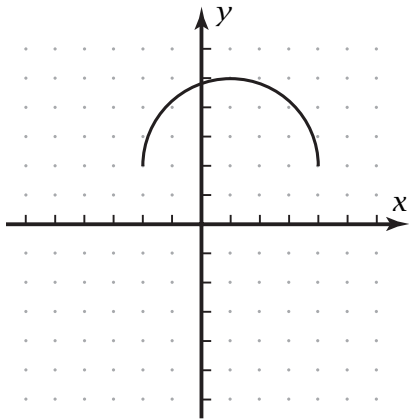

8.

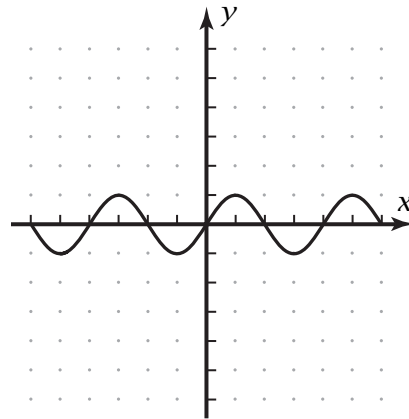

Problem Set 1-6/Page 47

7d.

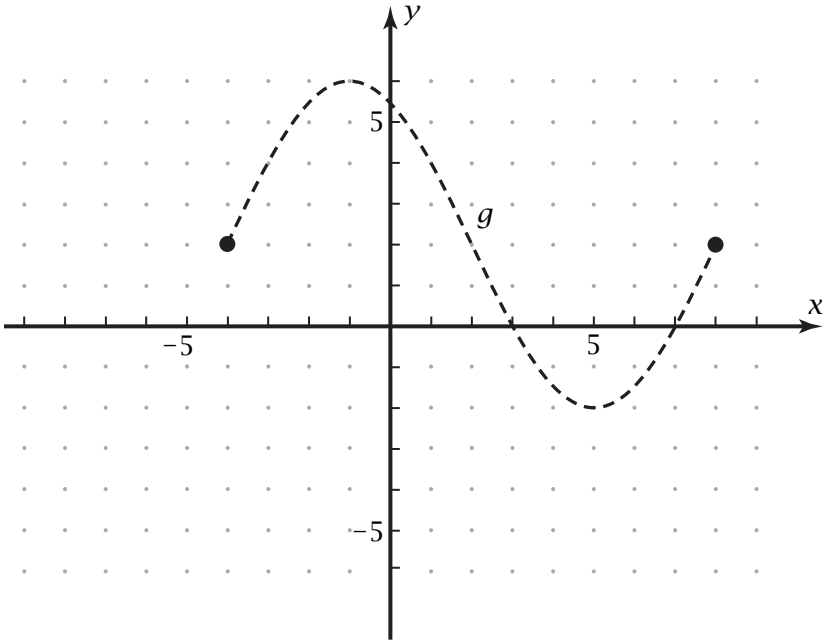

Figure 1-6i

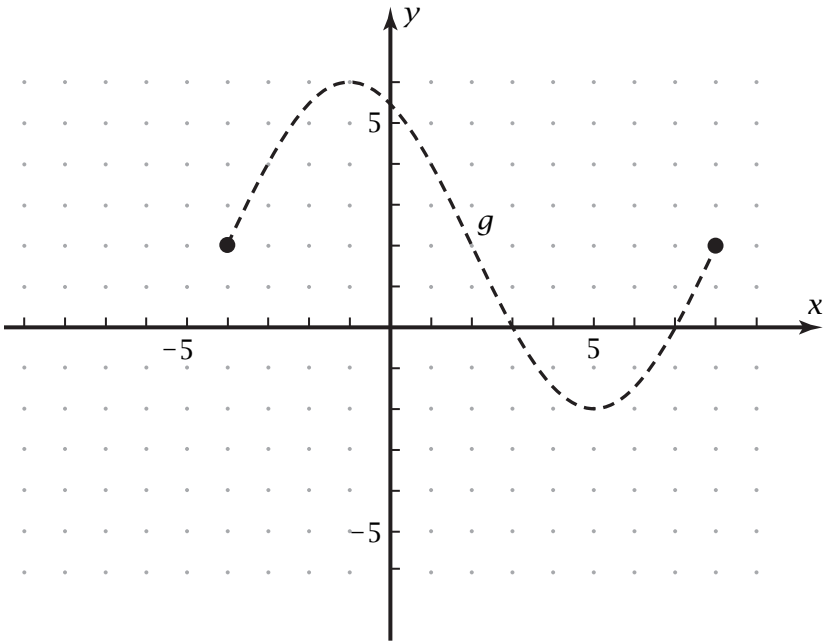

Figure 1-6i

Problem Set 1-8/Pages 53-56

R3b.

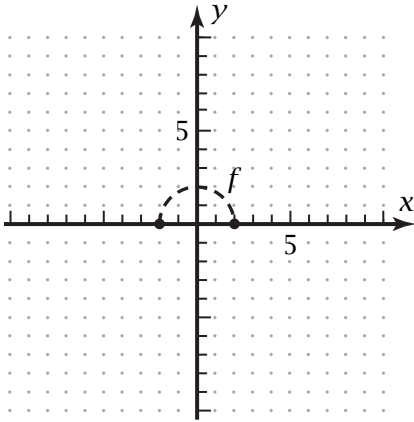

Figure 1-8h

C2d.

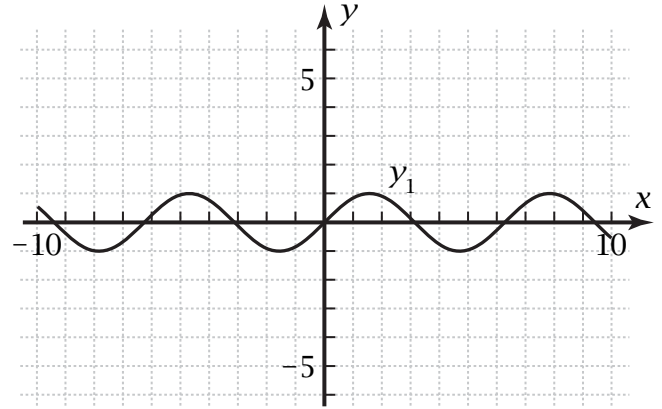

Figure 1-8m

R5a.

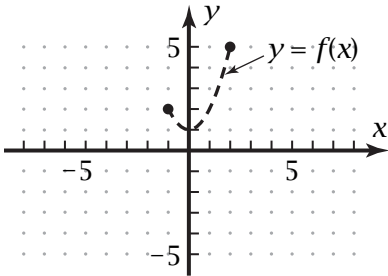

Figure 1-8i

R5d.

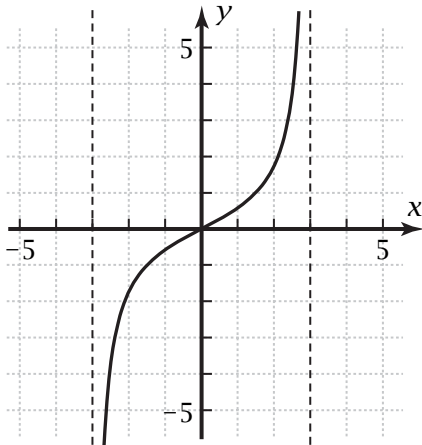

Figure 1-8j

Problem Set 2-3/Pages 71-72

Example 3

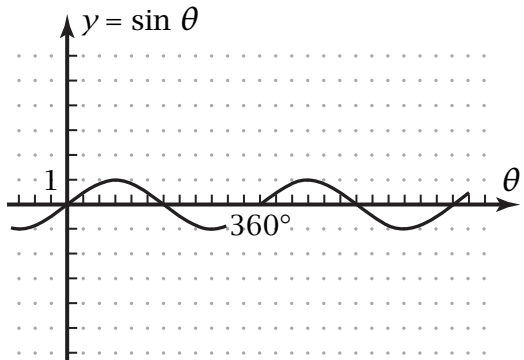
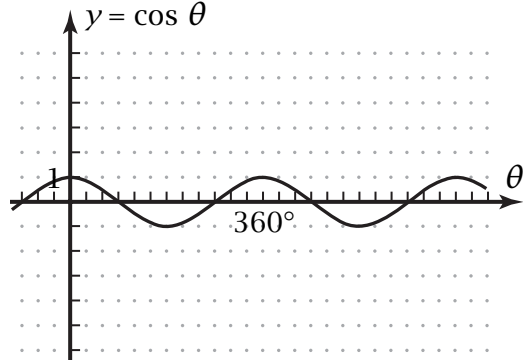
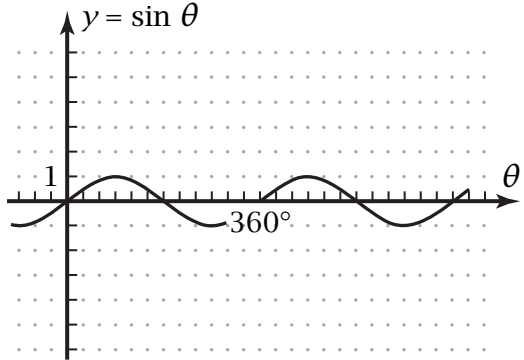

Figure 2-3i

17.



15.



18.

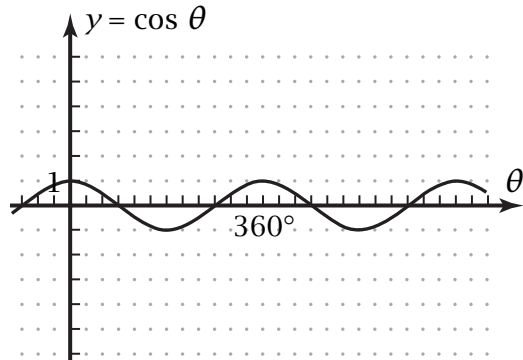

16.

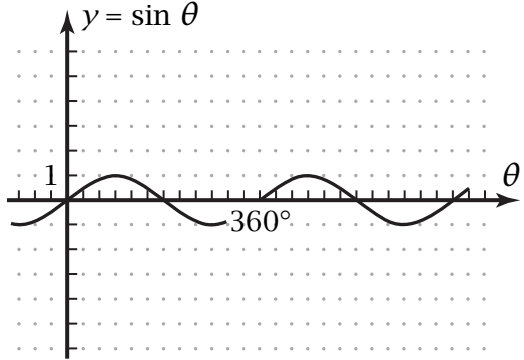

19.

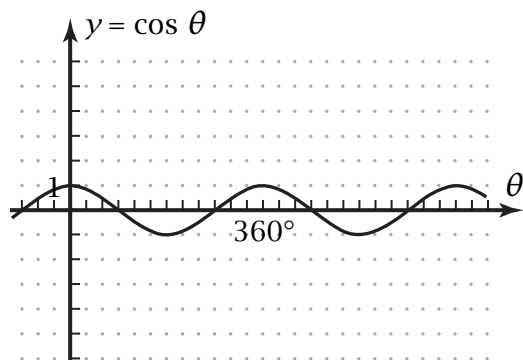

20.

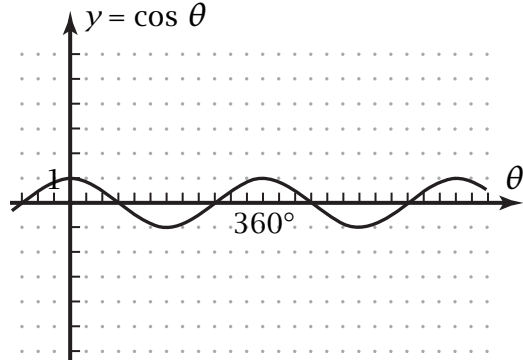

Trigonometric Ratios Table

Fill in this table as you work through Chapters 2 and 3. Wait until you have encountered each particular concept before filling in the column below it. For example, you will learn about sine and cosine in Section 2-3, but you won't learn about radians until Section 3-4.

Degrees	Radians	Sine	Cosine	Tangent	Cotangent	Secant	Cosecant
0°							
30°							
45°							
60°							
90°							
120°							
135°							
150°							
180°							
210°							
225°							
240°							
270°							
300°							
315°							
330°							
360°							

Problem Set 3-2/Pages 103-105

5.

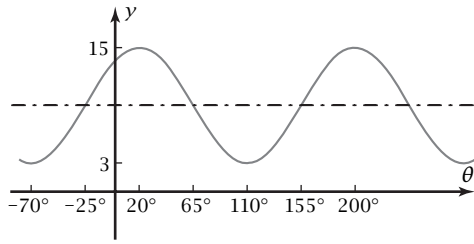

9.

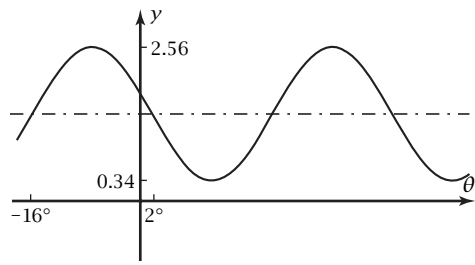

6.

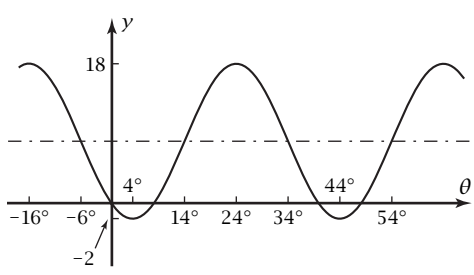

10.

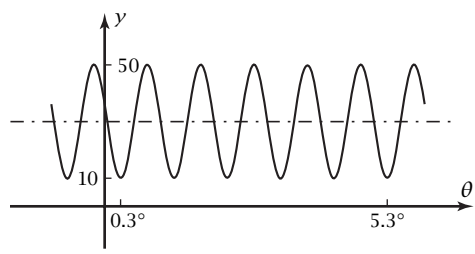

7.

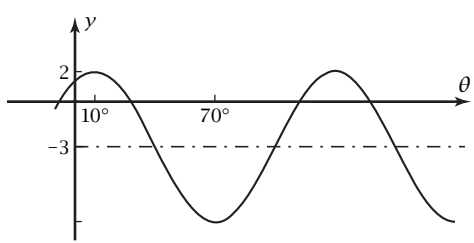

11.

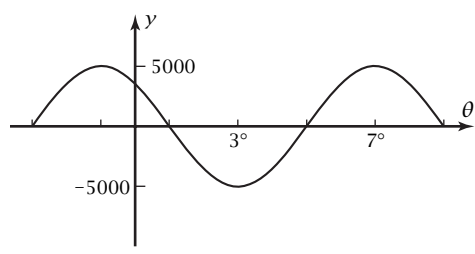

8.

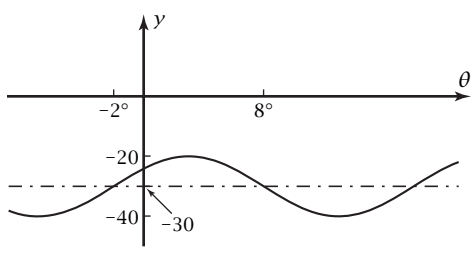

12.

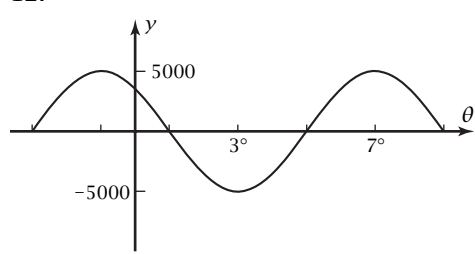

Problem Set 3-2/Pages 103-105

13.

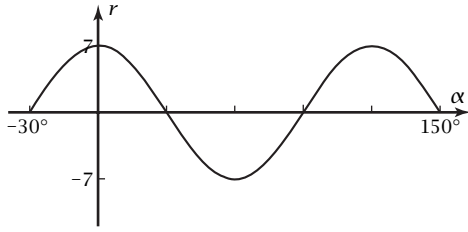

17.

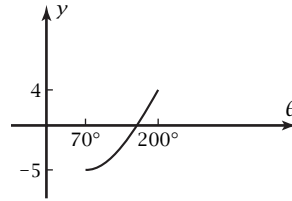

14.

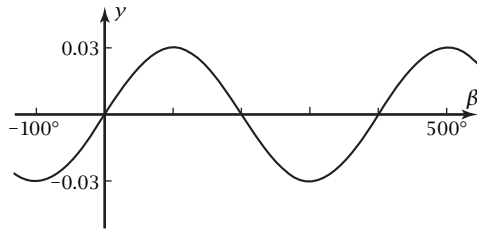

18.

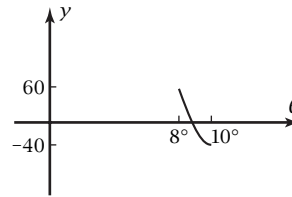

15.

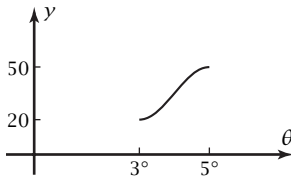

23.

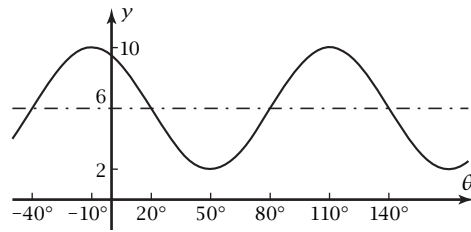

16.

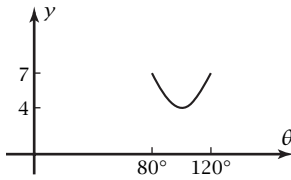

24.

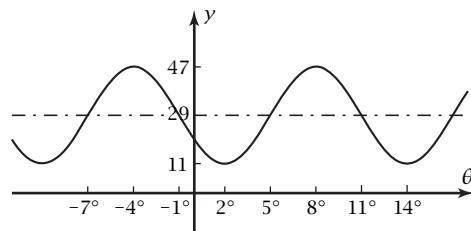

Problem Set 3-4/Page 117

49.

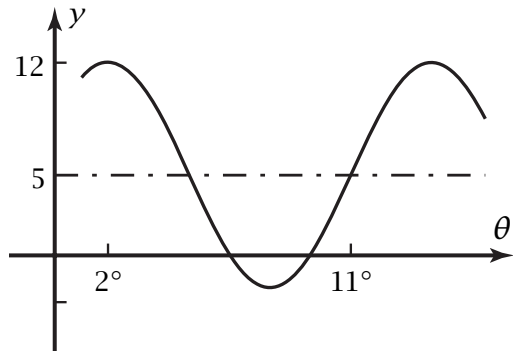

50.

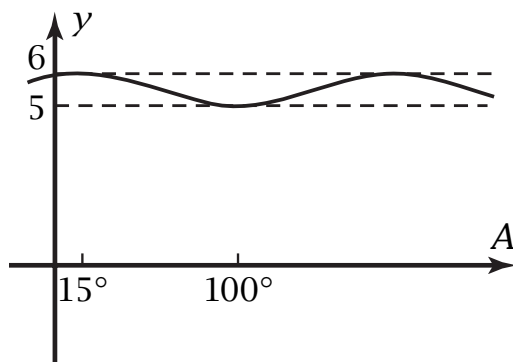

Problem Set 3-9/Page 153

T1., T2.

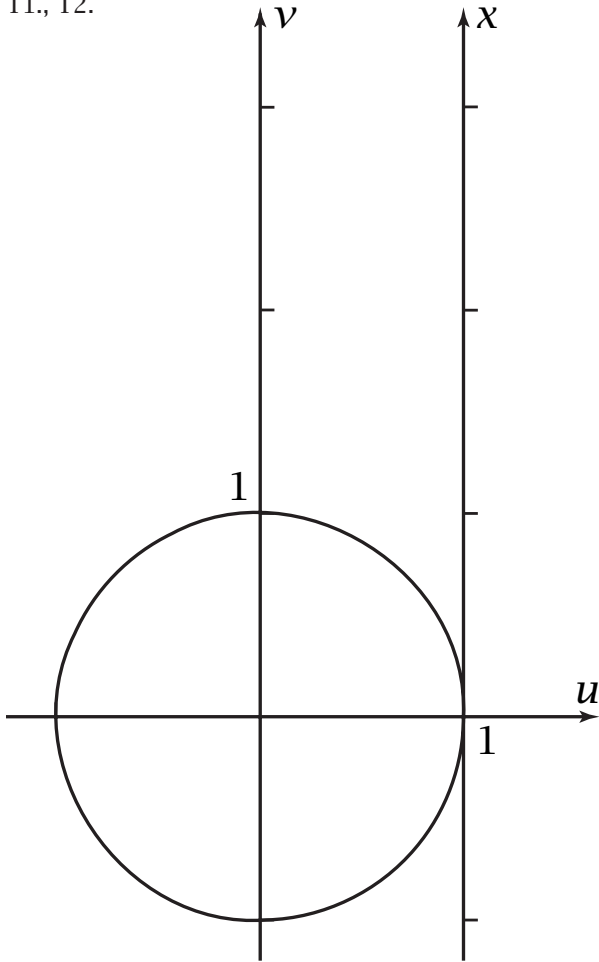

Figure 3-8g

Problem Set 5-4/Pages 214-215, 219

Example 1

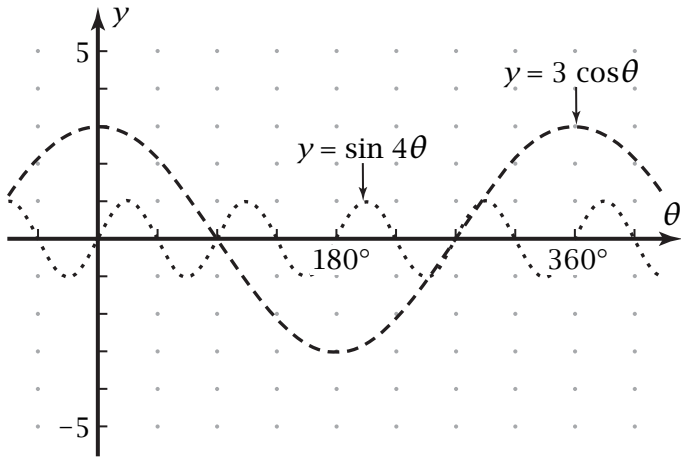

Figure 5-4d

1b.

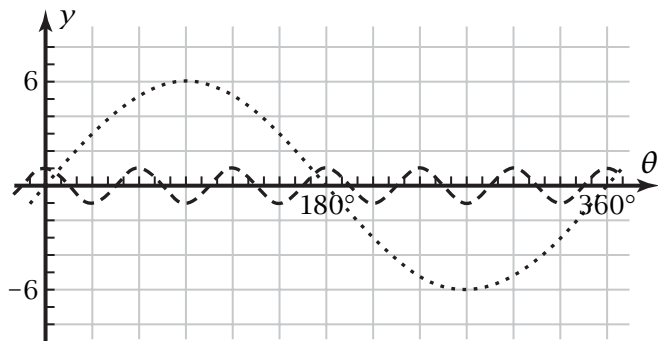

Figure 5-4n

2a.

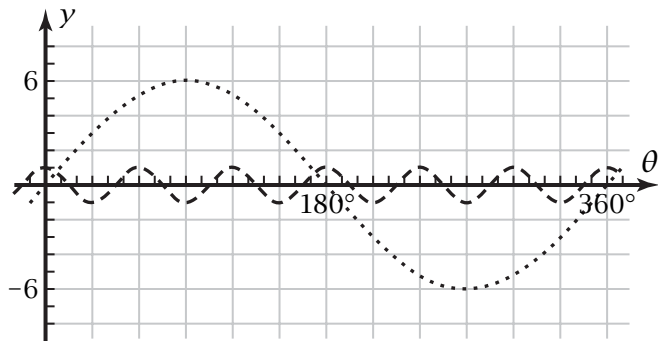
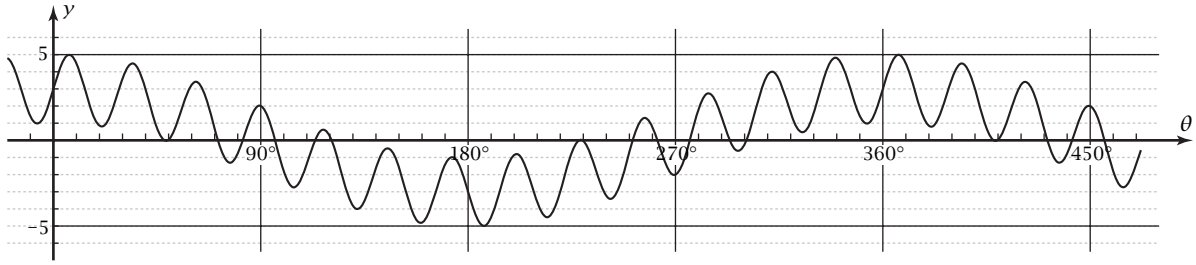

Figure 5-4n

Problem Set 5-4/Page 220

3.



4.

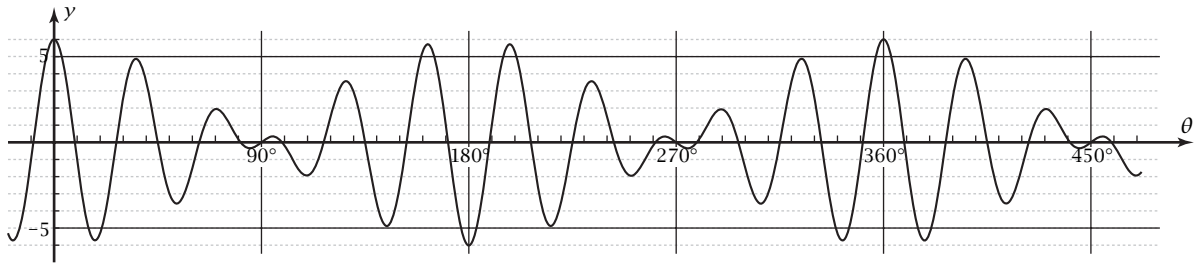

5.

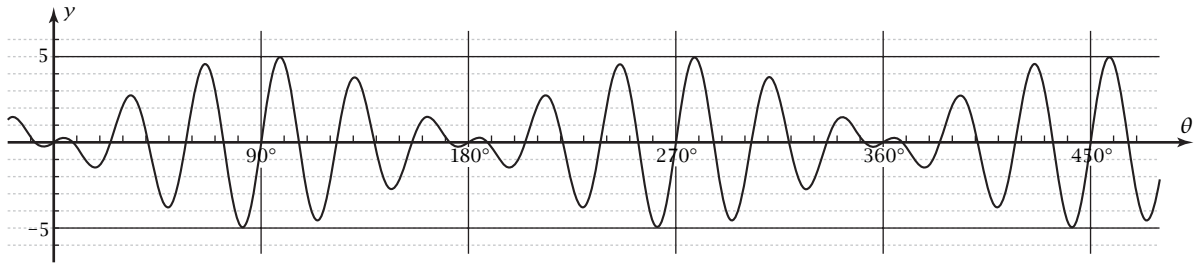

6.

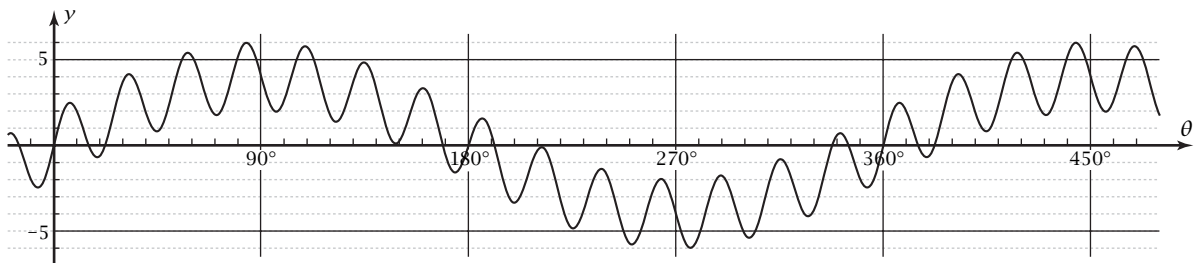

7.

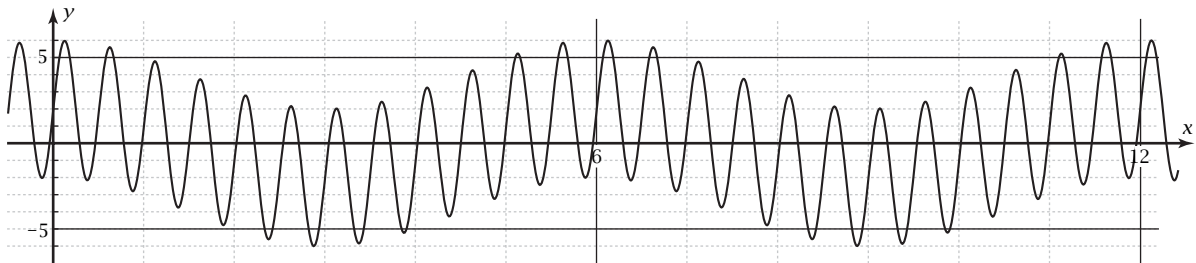

Problem Set 5-4/Page 221

8.

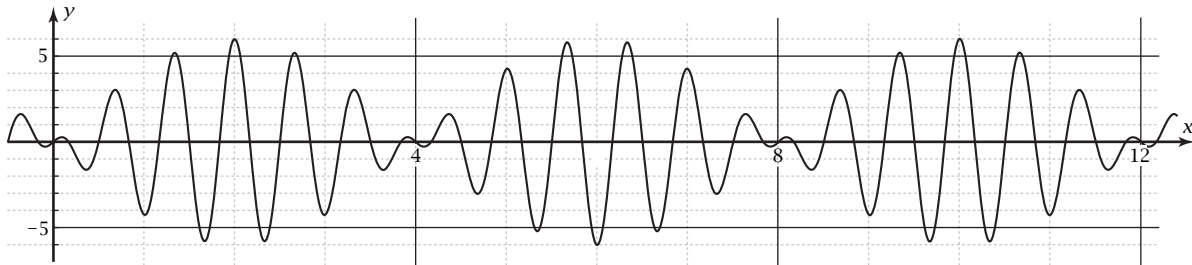

9.

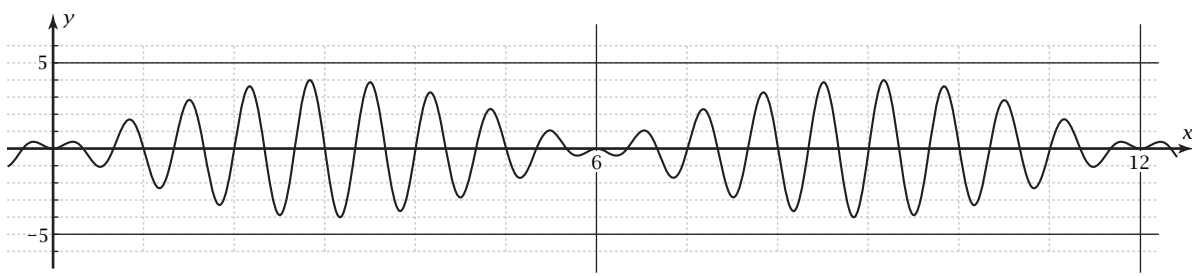

10.

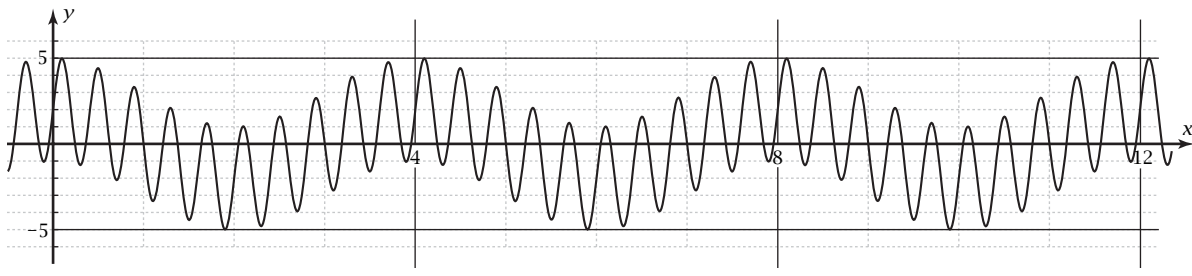

11.

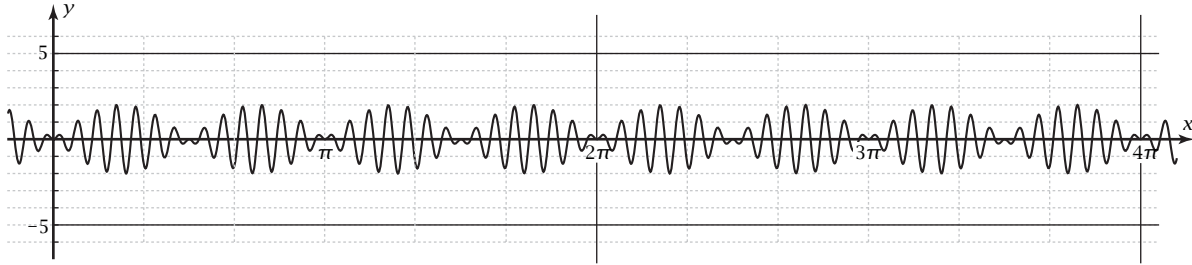

12.

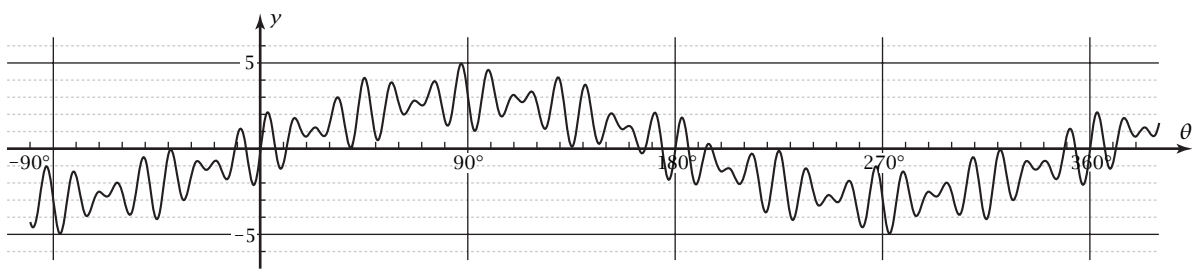

Problem Set 5-5/Pages 226-229

Example 3

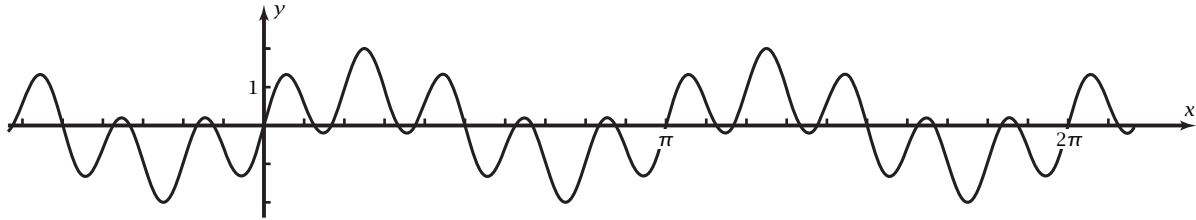
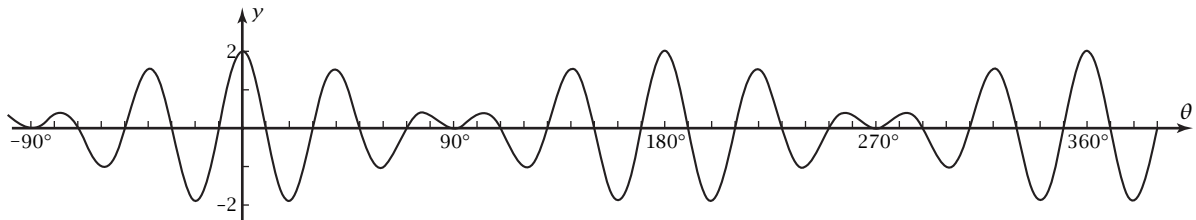
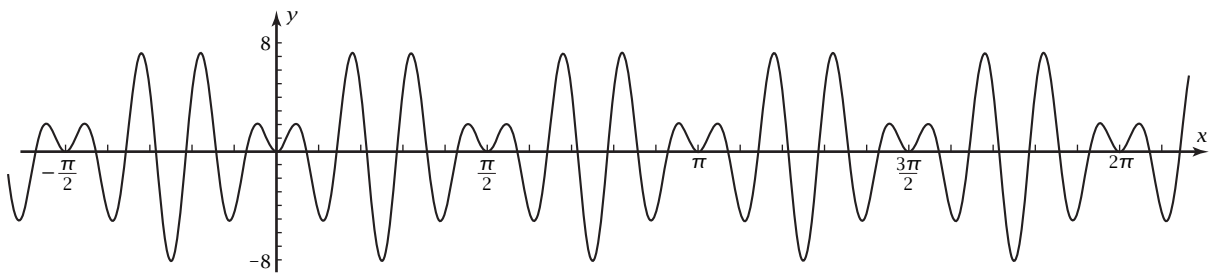

Figure 5-5d

17.



18.



19.

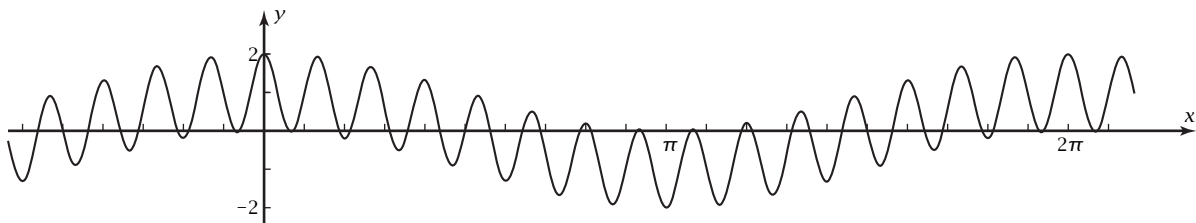

20.

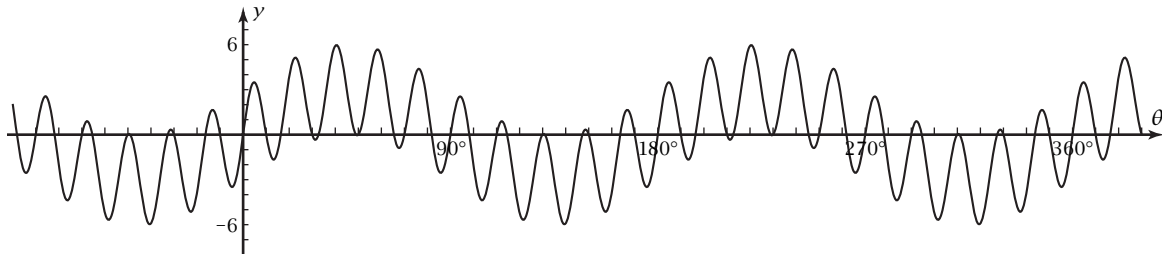

Problem Set 5-7/Pages 242, 246

R4a.

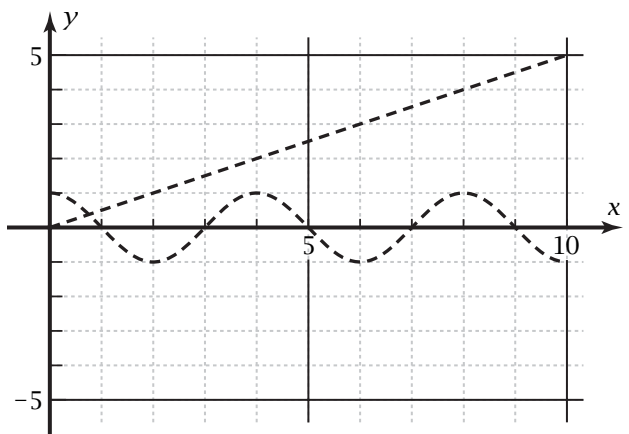

Figure 5-7e

R4b.

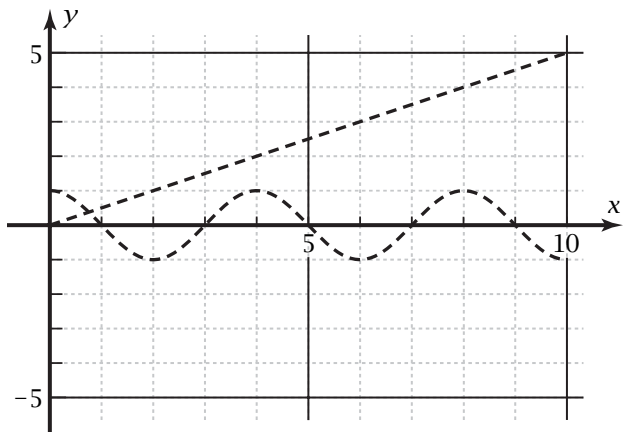

Figure 5-7e

T14.

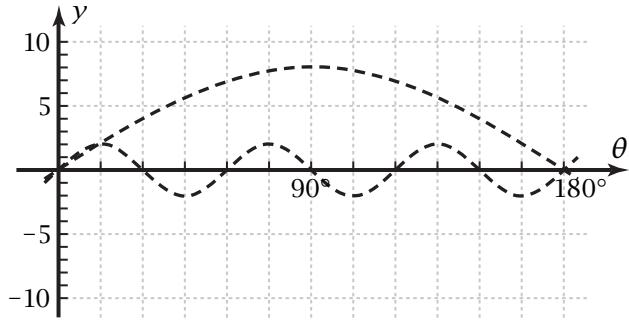

Figure 5-7o

Summary of Trigonometric Function Properties**Reciprocal Properties**

$$\cot x = \frac{1}{\tan x} \quad \text{or} \quad \tan x \cot x = 1$$

$$\sec x = \frac{1}{\cos x} \quad \text{or} \quad \cos x \sec x = 1$$

$$\csc x = \frac{1}{\sin x} \quad \text{or} \quad \sin x \csc x = 1$$

Quotient Properties

$$\tan x = \frac{\sin x}{\cos x} = \frac{\sec x}{\csc x}$$

$$\cot x = \frac{\cos x}{\sin x} = \frac{\csc x}{\sec x}$$

Pythagorean Properties

$$\cos^2 x + \sin^2 x = 1$$

$$1 + \tan^2 x = \sec^2 x$$

$$\cot^2 x + 1 = \csc^2 x$$

Odd-Even Function Properties

$$\sin(-x) = -\sin x \text{ (odd function)}$$

$$\cos(-x) = \cos x \text{ (even function)}$$

$$\tan(-x) = -\tan x \text{ (odd function)}$$

$$\cot(-x) = -\cot x \text{ (odd function)}$$

$$\sec(-x) = \sec x \text{ (even function)}$$

$$\csc(-x) = -\csc x \text{ (odd function)}$$

Cofunction Properties

$$\cos(90^\circ - \theta) = \sin \theta, \cos\left(\frac{\pi}{2} - x\right) = \sin x$$

$$\cot(90^\circ - \theta) = \tan \theta, \cot\left(\frac{\pi}{2} - x\right) = \tan x$$

$$\csc(90^\circ - \theta) = \sec \theta, \csc\left(\frac{\pi}{2} - x\right) = \sec x$$

Linear Combination of Cosine and Sine

$$b \cos x + c \sin x = A \cos(x - D), \text{ where}$$

$$A = \sqrt{b^2 + c^2} \text{ and } D = \arctan \frac{c}{b}$$

Composite Argument Properties

$$\cos(A - B) = \cos A \cos B + \sin A \sin B$$

$$\cos(A + B) = \cos A \cos B - \sin A \sin B$$

$$\sin(A - B) = \sin A \cos B - \cos A \sin B$$

$$\sin(A + B) = \sin A \cos B + \cos A \sin B$$

$$\tan(A - B) = \frac{\tan A - \tan B}{1 + \tan A \tan B}$$

$$\tan(A + B) = \frac{\tan A + \tan B}{1 - \tan A \tan B}$$

Sum and Product Properties

$$2 \cos A \cos B = \cos(A + B) + \cos(A - B)$$

$$2 \sin A \sin B = -\cos(A + B) + \cos(A - B)$$

$$2 \sin A \cos B = \sin(A + B) + \sin(A - B)$$

$$2 \cos A \sin B = \sin(A + B) - \sin(A - B)$$

$$\cos x + \cos y = 2 \cos \frac{1}{2}(x + y) \cos \frac{1}{2}(x - y)$$

$$\cos x - \cos y = -2 \sin \frac{1}{2}(x + y) \sin \frac{1}{2}(x - y)$$

$$\sin x + \sin y = 2 \sin \frac{1}{2}(x + y) \cos \frac{1}{2}(x - y)$$

$$\sin x - \sin y = 2 \cos \frac{1}{2}(x + y) \sin \frac{1}{2}(x - y)$$

Double Argument Properties

$$\sin 2x = 2 \sin x \cos x$$

$$\cos 2x = \cos^2 x - \sin^2 x = 1 - 2 \sin^2 x$$

$$= 2 \cos^2 x - 1$$

$$\tan 2x = \frac{2 \tan x}{1 - \tan^2 x}$$

$$\sin^2 x = \frac{1}{2}(1 - \cos 2x)$$

$$\cos^2 x = \frac{1}{2}(1 + \cos 2x)$$

Half Argument Properties

$$\sin \frac{1}{2}x = \pm \sqrt{\frac{1}{2}(1 - \cos x)}$$

$$\cos \frac{1}{2}x = \pm \sqrt{\frac{1}{2}(1 + \cos x)}$$

$$\tan \frac{1}{2}x = \pm \sqrt{\frac{1 - \cos x}{1 + \cos x}}$$

$$= \frac{\sin x}{1 + \cos x} = \frac{1 - \cos x}{\sin x}$$

Problem Set 6-9/Page 286

4.

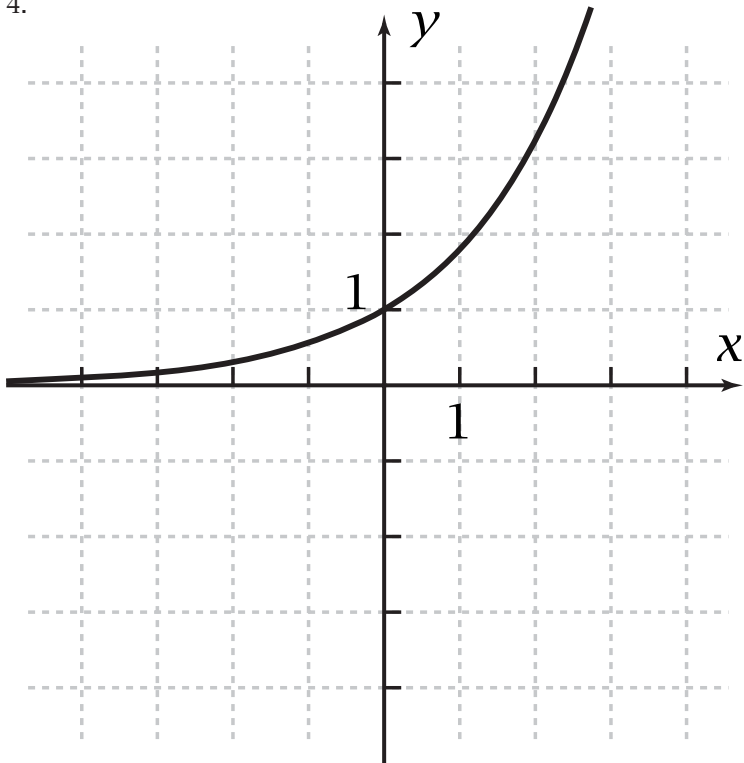

Figure 6-9b

Problem Set 7-8/Pages 347-348

C3c., C3e.

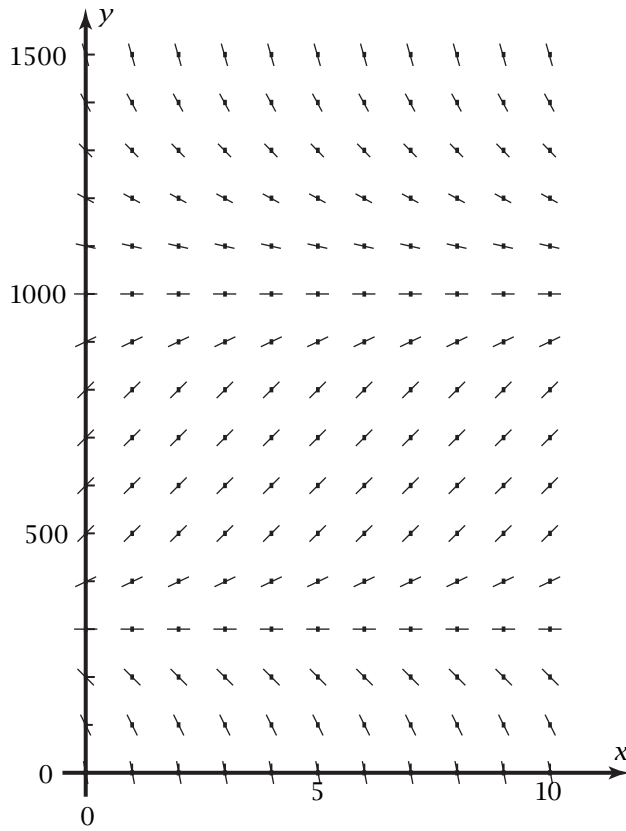

Figure 7-7f

Problem Set 8-3/Page 363

1b.

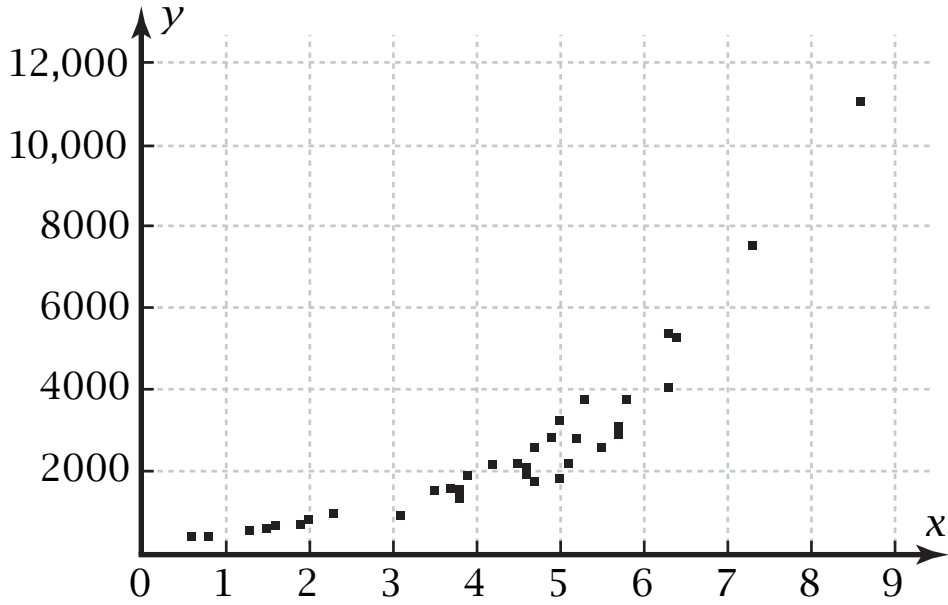

Figure 8-3i

Problem Set 8-4/Pages 378-380

19.

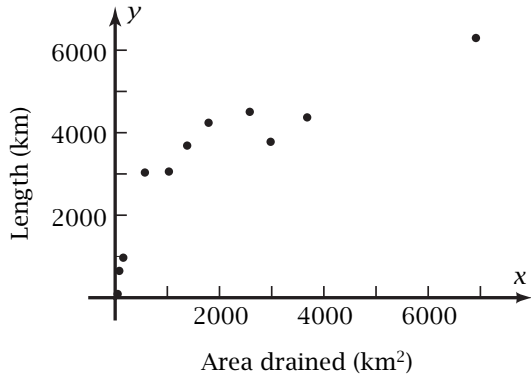

Figure 8-4k

21.

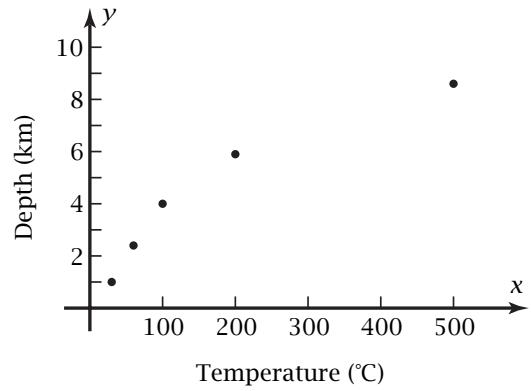

Figure 8-4m

20.

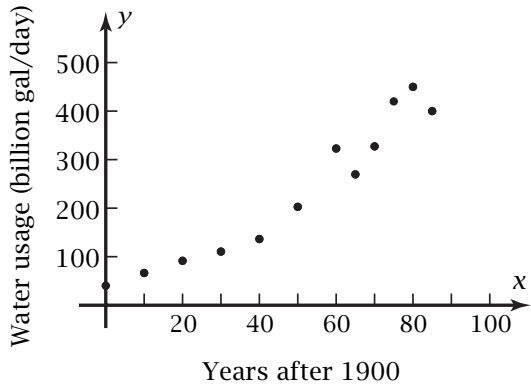

Figure 8-4l

22.

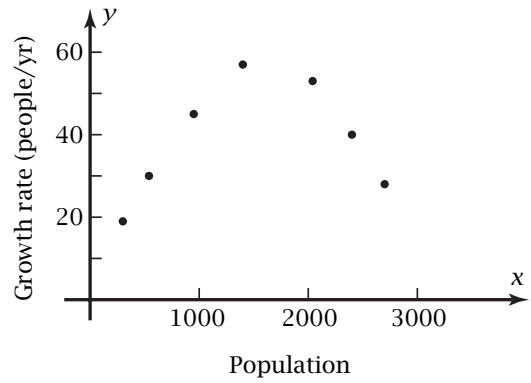

Figure 8-4n

Problem Set 8-6/Page 390

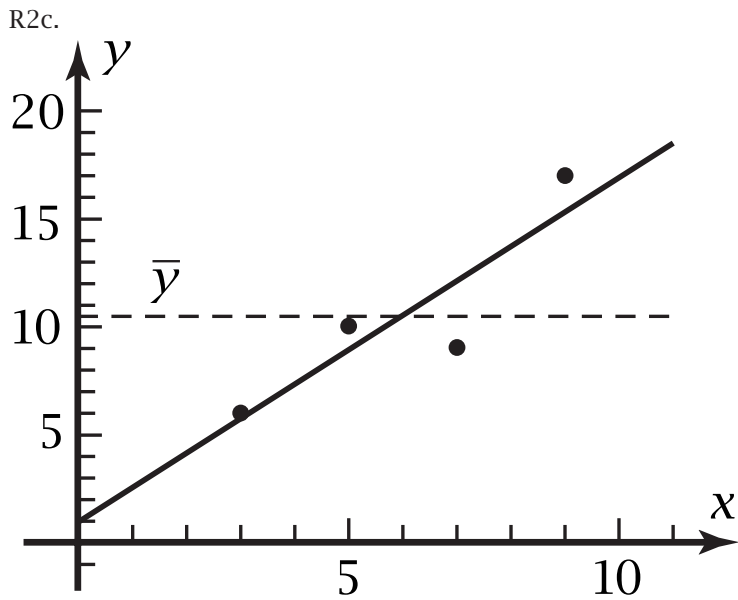

Figure 8-6b

Problem Set 10-1/Page 451

3.

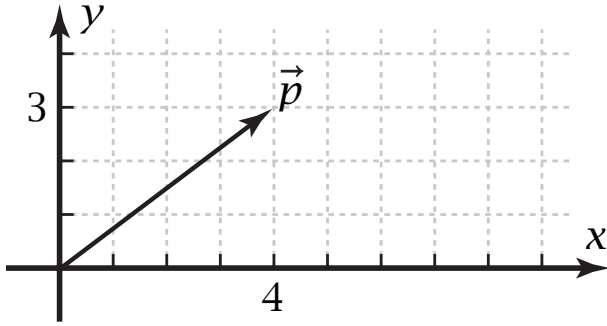
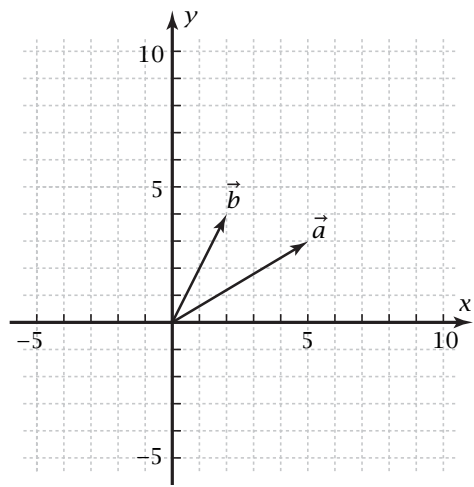

Figure 10-1b

Problem Set 10-2/Pages 458-459

1.



3.

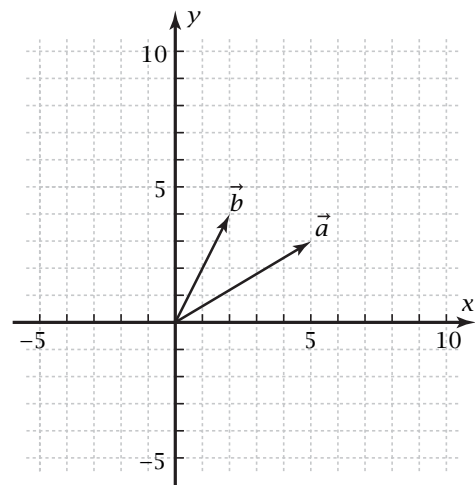

2.

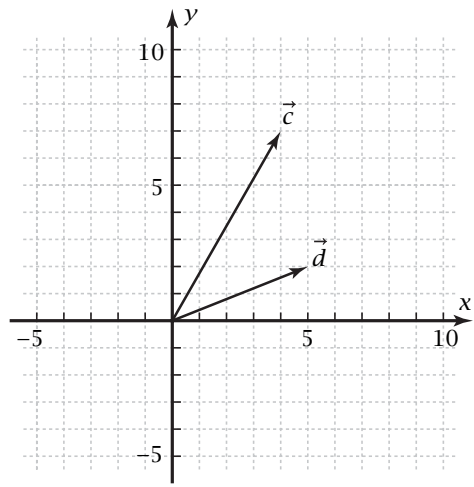

4.

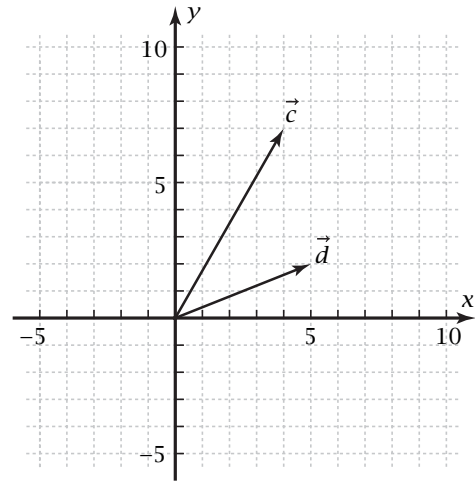

Problem Set 10-9/Pages 496, 499

R1b.

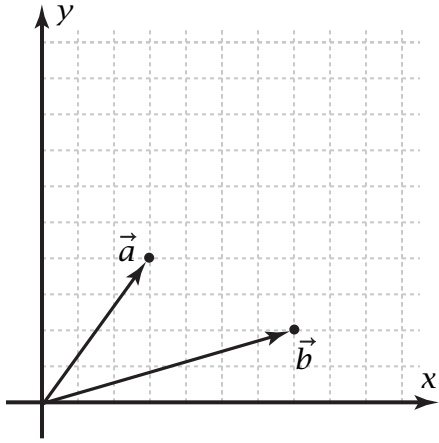

Figure 10-9a

T1.

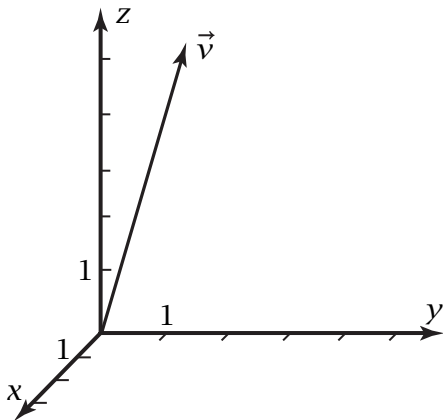

Figure 10-9f

T2.

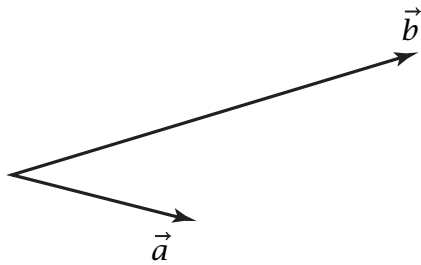

Figure 10-9g

Problem Set 11-4/Pages 521-522

3b.

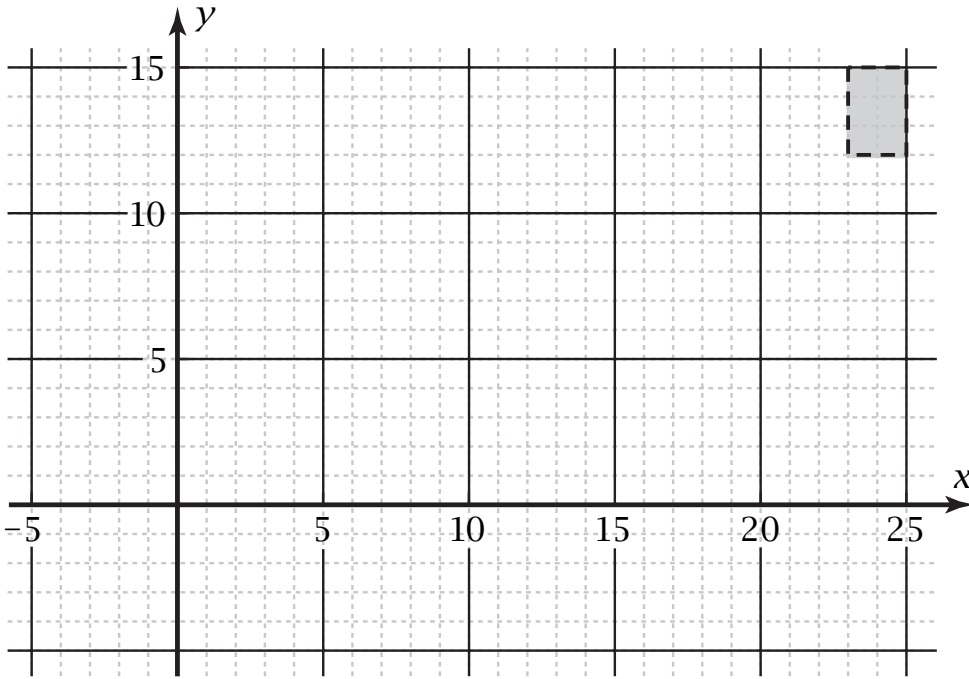

Figure 11-4d

3d.

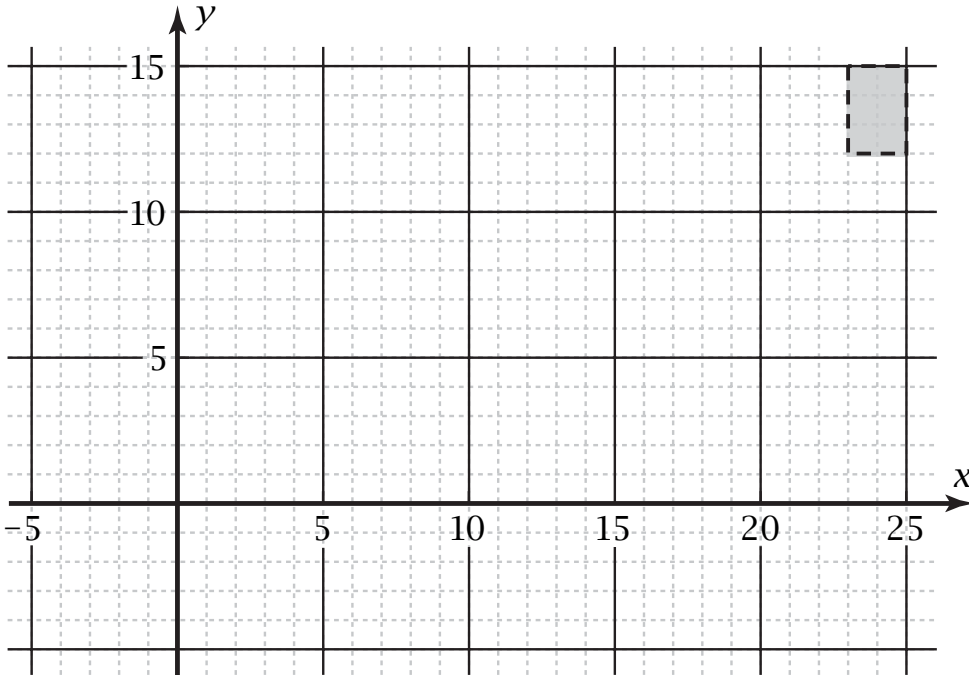

Figure 11-4d

Problem Set 11-5/Pages 529-530

10e.

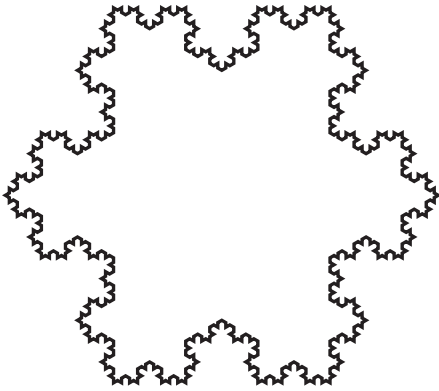

Figure 11-5q

Problem Set 11-7/Pages 538-541

R5d.

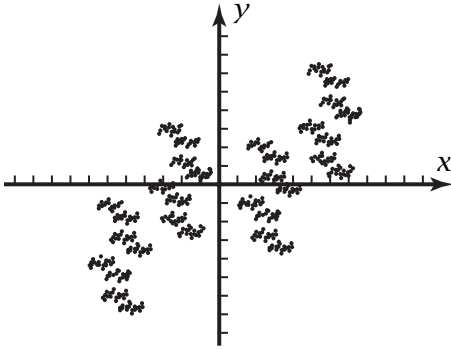

Figure 11-7c

R5e.

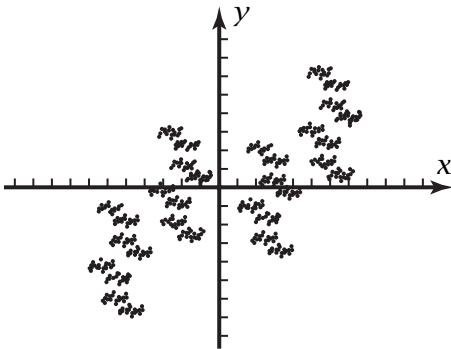

Figure 11-7c

C1b.

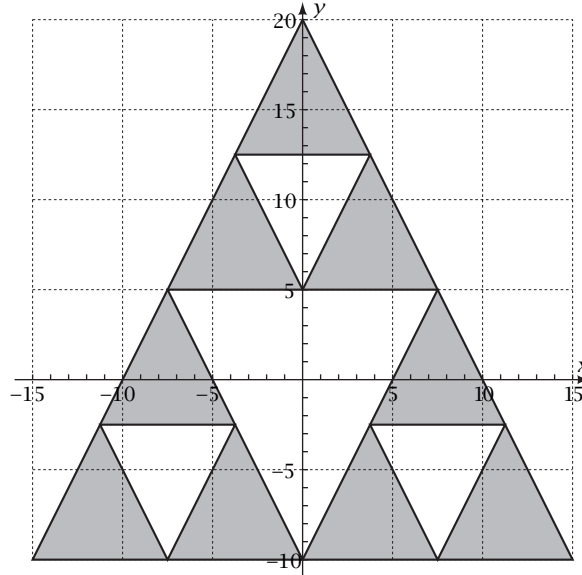

Figure 11-7d

T11.

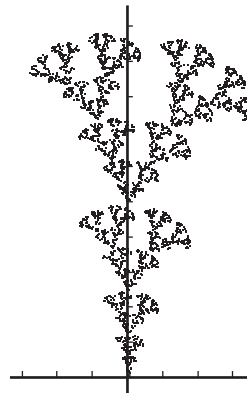
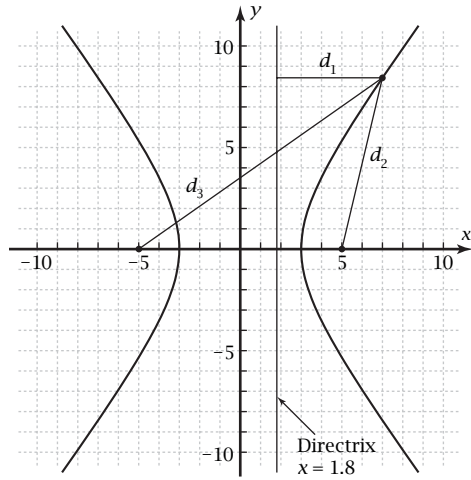

Figure 11-7f

Problem Set 12-4/Pages 576-577

1.



2.

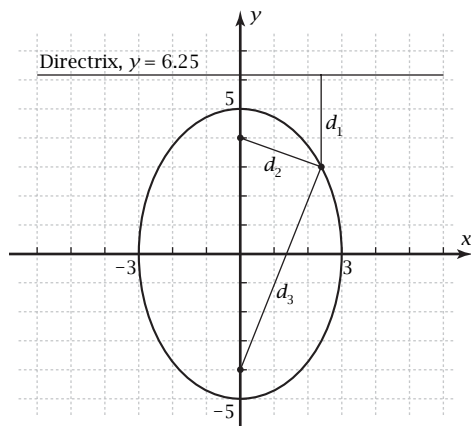

3.

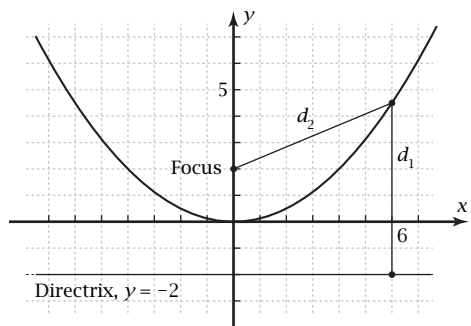

Problem Set 12-7/Page 592

R4.

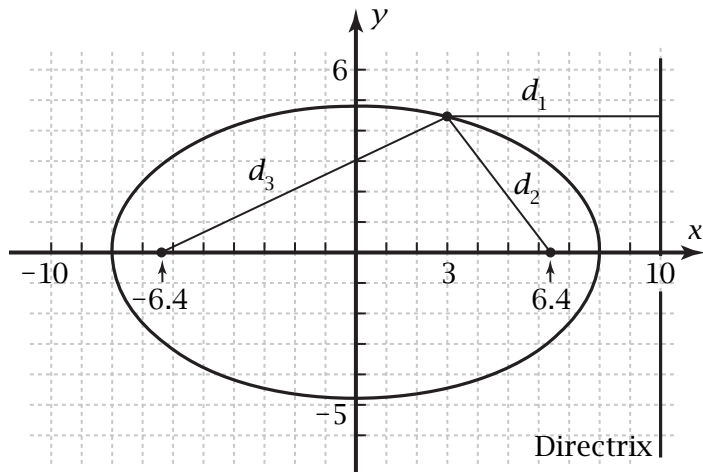

Problem Set 13-5/Pages 627-630

5.

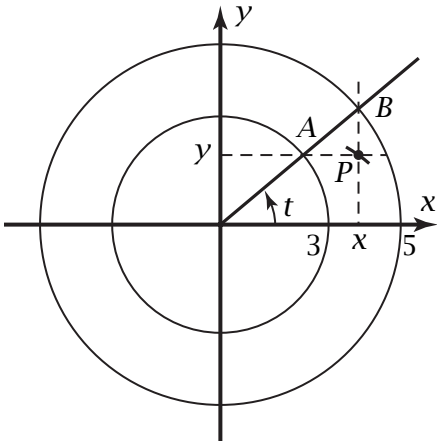

Figure 13-5i

6.

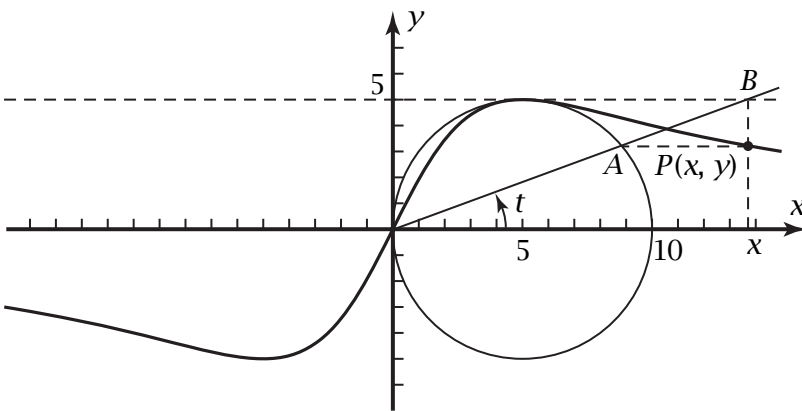

Figure 13-5j

7.

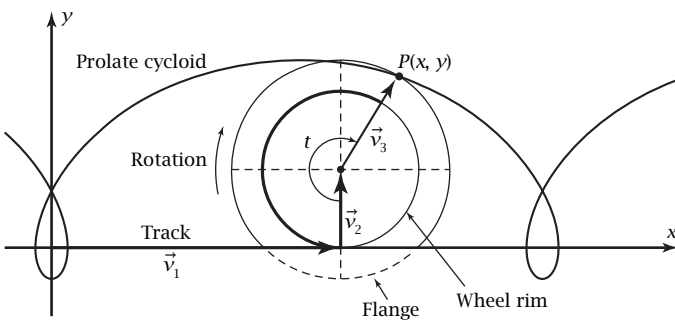

Figure 13-5k

Problem Set 13-5/Pages 627-630

8.

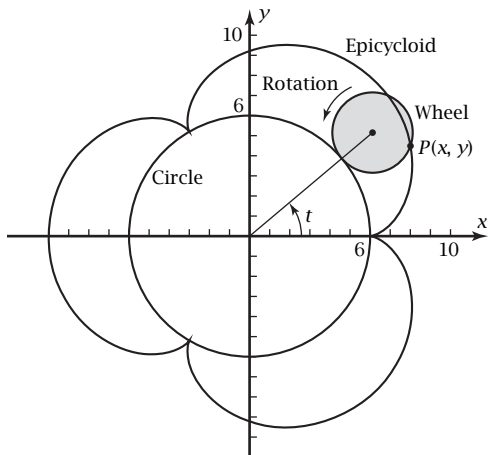

Figure 13-5l

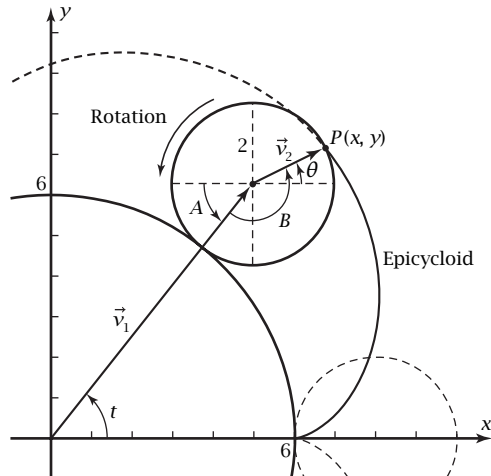

Figure 13-5m

9.

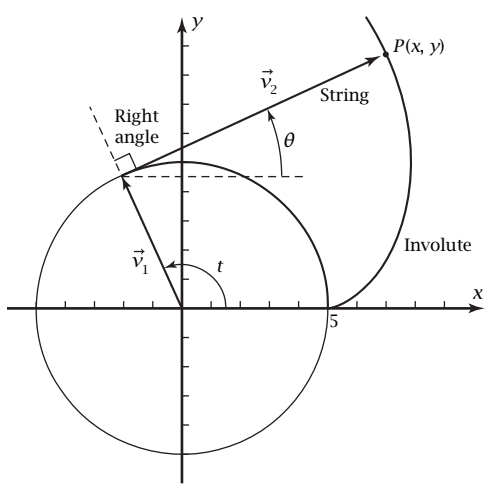

Figure 13-5n

10.

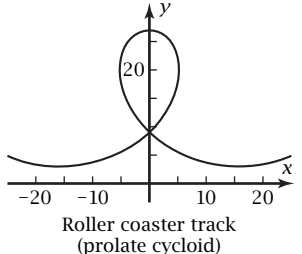

Figure 13-5o

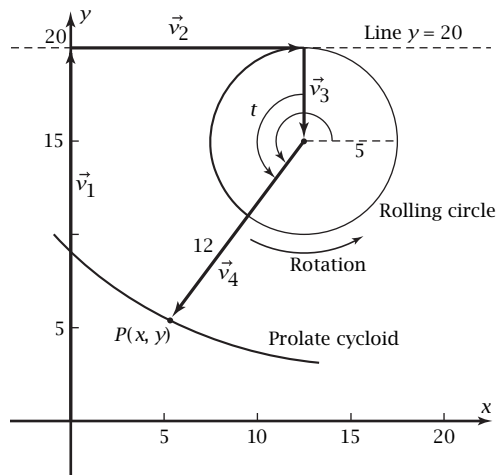

Figure 13-5p

Problem Set 15-5/Pages 698-699

3a.

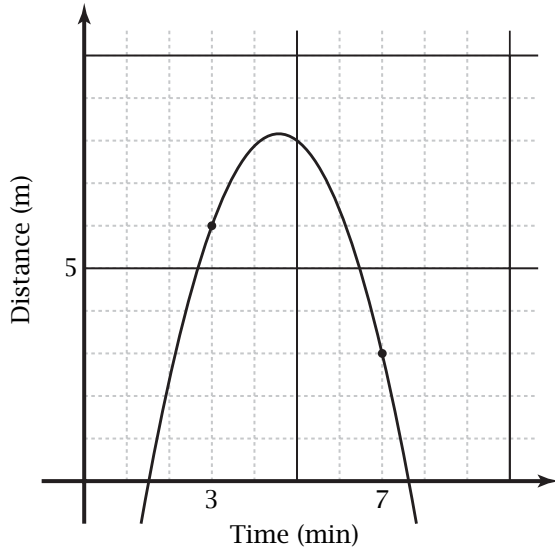

Figure 15-5e

4a.

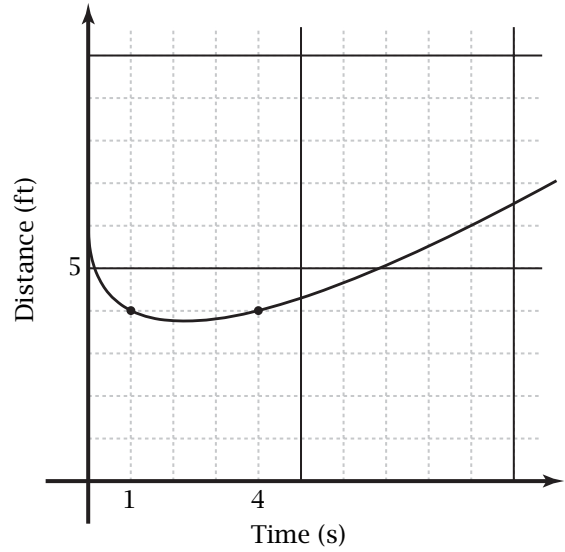

Figure 15-5f

5d.

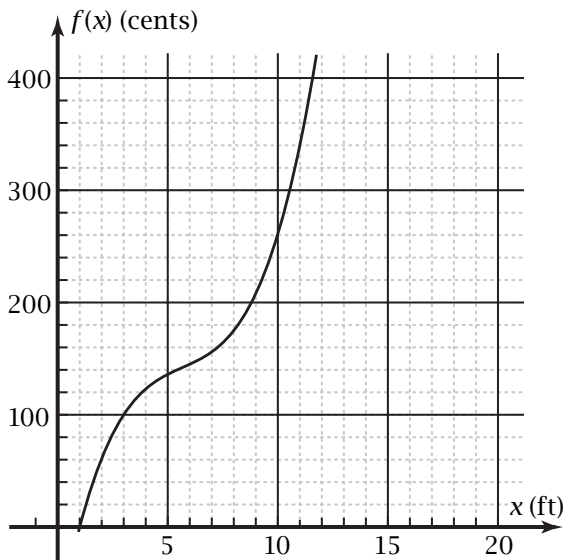

Figure 15-5g

6c.

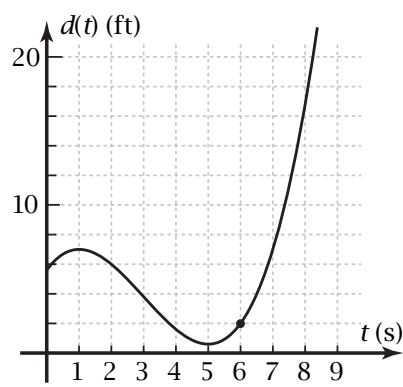

Figure 15-5h

Problem Set 15-6/Pages 704-707

R5.

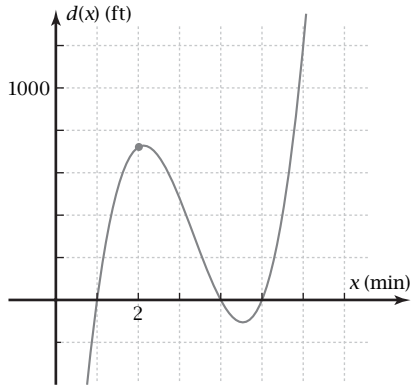

Figure 15-6c

C1c.

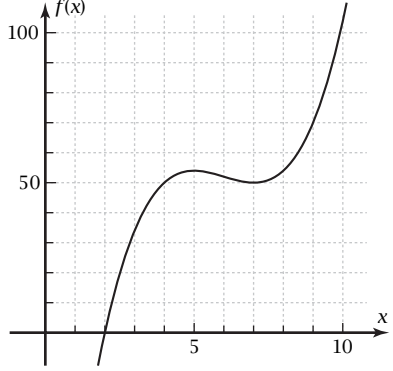

Figure 15-6d

C1d.

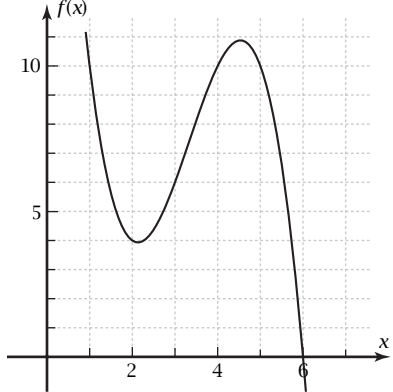

Figure 15-6e

T6.

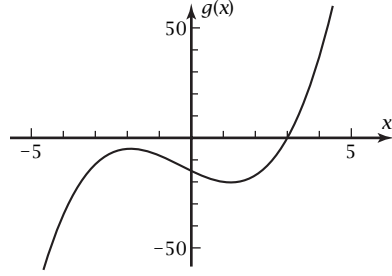

Figure 15-6f

T19.

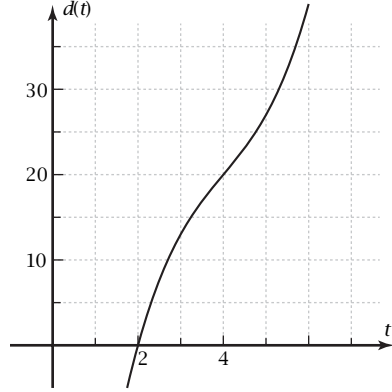

Figure 15-6g

Problem Set 15-7/Pages 709-712

13.

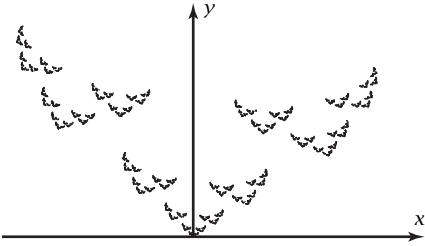

Figure 15-7a

25.

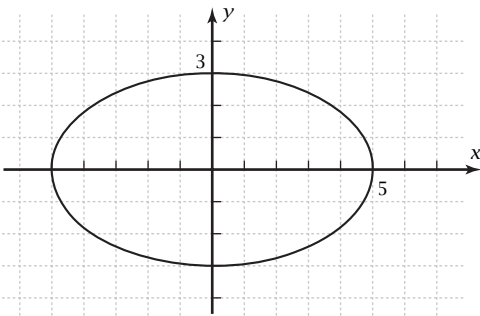

Figure 15-7c

46.

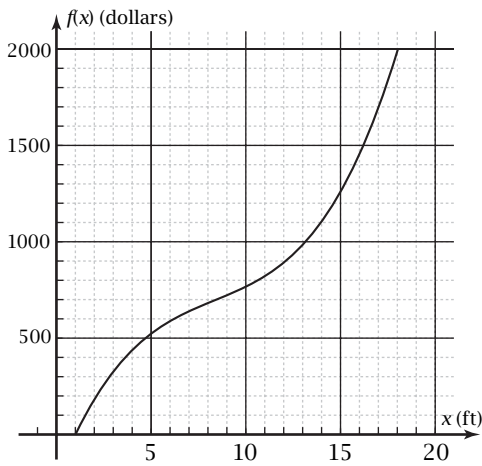

Figure 15-7g

